

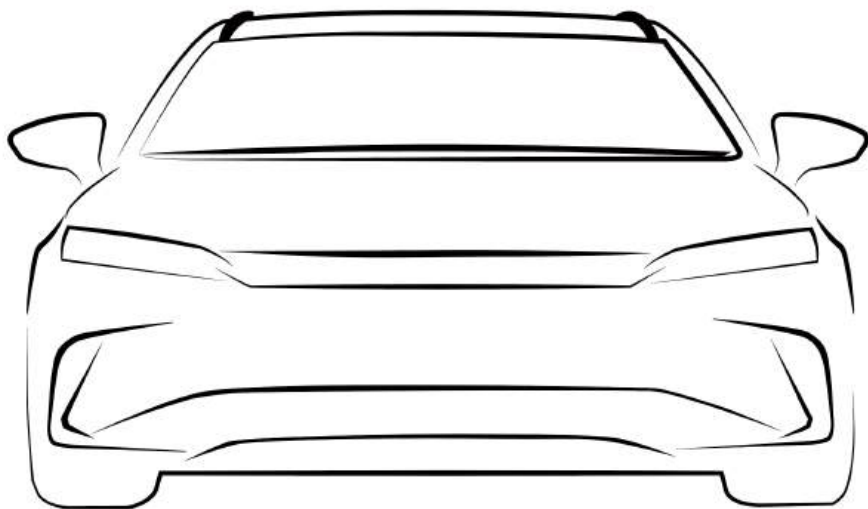

HAN EV

OWNER'S MANUAL



BUILD YOUR DREAMS

Foreword

Thank you for choosing BYD. To better use and maintain the vehicle, please read this manual carefully and keep it for future reference.

Special instructions: BYD Auto Industry Co., Ltd. recommends that you choose genuine spare parts and use, maintain, and repair the vehicle in accordance with this manual. The use of non-genuine spare parts to replace or modify the vehicle will affect the performance of the entire vehicle, especially its safety and durability. Vehicle damage and performance issues caused thereby will not be covered by the warranty. In addition, vehicle modifications may also violate national laws and regulations and local government regulations.

Thank you again for choosing BYD. Your valuable comments and suggestions are welcome. To enjoy better services, please provide your accurate contact information. If there is any change to the information, contact a BYD authorized dealer or service provider in a timely manner to update the information in the system. You are also advised to pay attention to the relevant national laws and regulations and local policies, and register the vehicle as soon as possible; otherwise vehicle registration may fail.

Pay attention to the "REMINDER", "CAUTION" and "WARNING" symbols in this manual, and follow the instructions carefully to avoid injury or damage. These symbols are defined as follows:



REMINDER

Items that must be observed to facilitate maintenance.



CAUTION

Items that must be observed to avoid damage to the vehicle.



WARNING

Items that must be observed to ensure personal safety.



 is a safety mark to indicate an operation that should not be performed or an event that should not happen.

The descriptions marked with the asterisk (*) in this manual are specific to some model configurations, and applicable only when the vehicle has these configurations. The picture

used is taken from one of these configurations. If there is any difference from the vehicle you purchased, refer to the actual vehicle.

This manual is expected to help you use the product correctly, and does not provide any description of the configuration and software version of this product. For details about the product configuration and software version, please refer to the contract (if any) related to this product, or consult the dealer who sold the product to you.

Sustainability

As a pure electric passenger vehicle, the BYD HAN EV is an environmentally friendly product. Please visit <https://reach.bydeurope.com> for environmental protection information about the vehicle.

It is everyone's responsibility to protect the environment. Please use this vehicle properly and dispose of any waste and cleaning materials according to the corresponding local laws and regulations.

Contact Us

If you require assistance or clarification on policies or procedures, please contact the customer service center.

E-mail: Autoservice.contact@byd.com

Call 00800-10203000 for 24/7 roadside assistance or customer service(Monday-Saturday 9:00-18:00).

Copyright © BYD Auto Industry Co., Ltd. All rights reserved.

No part of this document may be reproduced, copied, stored, translated, or transmitted electronically or in any other form without prior written consent and authorization of BYD Auto Industry Co., Ltd.

All rights reserved

Illustration Index

Exterior.....	7
Dashboard.....	8
Interior.....	9
Doors.....	10

Safety

Seat Belts.....	12
Seat Belt Overview.....	12
Using Seat Belts.....	13
Airbags.....	15
Airbags.....	15
Driver and Front Passenger Airbags.....	16
Knee Airbags.....	17
Seat Side Airbags.....	17
Side Curtain Airbags.....	18
Airbag Triggering Conditions and Precautions.....	18
Child Restraint Systems.....	23
Child Restraint Systems.....	23
Installing Child Restraint Systems.....	24
Anti-theft Alarm System*.....	27
Anti-theft Alarm System*.....	27
Data Collection and Processing.....	28
Data Collection and Processing.....	28

Instrument Cluster

Instrument Cluster.....	34
Instrument Cluster View.....	34
Instrument Cluster Indicators.....	35

Controller Operation

Doors and Keys.....	46
Keys.....	46
Locking/Unlocking Doors.....	48
Smart Access and Start System.....	53
Child Protection Lock.....	55
Seats.....	55
Seat Precautions.....	55
Front Seats.....	56
Rear Seats.....	59
Steering Wheel.....	60
Steering Wheel Switches.....	60
Adjusting the Steering Wheel.....	62
Switches.....	64
Light Switches.....	64
Wiper Switches.....	68
Driver's Door Switches.....	69
Odometer Switch.....	71
Mode Switches.....	72
Hazard Warning Light Switch.....	73
Sunroof Switch.....	73
E-Call Switch.....	75
Interior Light Switch.....	75

Using and Driving

Charging/Discharging.....	78
Charging Instructions.....	78
Charging.....	82
External Discharging.....	89
Driving Range Display.....	91
Battery.....	91
High-Voltage Battery.....	91
Low-Voltage Battery.....	94

Usage Precautions.....	95
Break-in Period.....	95
Trailer Towing.....	95
Saving Energy and Extending Vehicle Service Life.....	95
Carrying Luggage.....	96
Wading into Water.....	97
Fire Prevention.....	98
Starting and Driving.....	99
Starting the Vehicle.....	99
Driving.....	100
Gear Shift Controls.....	101
Electronic Parking Brake (EPB).....	102
Automatic Vehicle Hold (AVH).....	105
Driving Precautions.....	106
Driver Assistance.....	107
Adaptive Cruise Control (ACC).....	107
Intelligent Cruise Control (ICC)*	111
Predictive Collision Warning (PCW)* & Automatic Emergency Braking (AEB)*	113
Traffic Sign Recognition (TSR)*	117
High Beam Assist (HMA)*	119
Lane Departure Assist (LDA)*	120
Emergency Steering Assist (ESA)*	122
Blind Spot Assist (BSA)*	123
Head-up Display (HUD)*	125
Tire Pressure Monitoring System (TPMS).....	125
Acoustic Vehicle Alerting System (AVAS).....	127
Panoramic View.....	128
Parking Assistance.....	129
Driving Safety Systems.....	132
Other Main Functions.....	136
Interior Rearview Mirror.....	136

Side Mirrors.....	137
Wiper Blades.....	138
Snow Chains.....	138

In-Vehicle Devices

Infotainment System.....	142
Infotainment Touchscreen.....	142
Navigation Bar.....	143
Gestures and Responses.....	143
BYD Assistant.....	143
Bluetooth Call.....	143
File Management.....	144
A/C System.....	144
A/C.....	144
Function Definitions.....	146
A/C Vents.....	149
Air Purification System.....	150
Switching on A/C with Cloud Service App*	151
BYD App.....	152
About BYD App.....	152
Account Registration.....	152
Vehicle Condition and Control.....	152
Individual Center and Vehicle Management.....	153
Storage.....	153
Glove Box.....	153
Cubby Box.....	153
Cup Holder.....	153
Glasses Case.....	154
Door Bins.....	154
Bill Box.....	154
Seatback Pockets.....	155
Other Devices.....	155
Sun Visor.....	155

Grab Handles..... 155
 12V Auxiliary Power..... 156
 USB Ports..... 156
 SD Card Slot..... 157
 Wireless Phone Charger..... 157

Maintenance

Maintenance Information..... 162
 Maintenance Cycle and Items..... 162
Regular Maintenance..... 164
 Regular Maintenance..... 164
 Vehicle Corrosion Prevention..... 165
 Paint Maintenance Tips..... 165
 Exterior Cleaning..... 166
 Interior Cleaning..... 167
Self-Maintenance..... 169
 Self-Maintenance..... 169
 Sunroof Maintenance..... 171
 Vehicle Storage..... 171
 Hood..... 172
 Cooling System..... 172
 Braking System..... 173
 Washing System..... 173
 A/C System..... 174
 Wiper Blades..... 174
 Tires..... 175
 Fuses..... 177

When Faults Occur

When Faults Occur..... 188
 If Smart Key Battery is Exhausted..... 188
 Emergency Shutdown System..... 188
 Vehicle Fire Rescue..... 189
 Battery Leakage Rescue..... 189

Collision Rescue..... 189
 If the Vehicle Needs Towing..... 190
 If a Tire Goes Flat..... 191
 Replacing Tires*..... 194

Specifications

Vehicle Data..... 200
 Vehicle Data..... 200
Information..... 203
 Vehicle Identification..... 203
 Warning Labels..... 204
 Declarations of Conformity..... 205

Abbreviations

Abbreviations..... 211

Illustration Index

Exterior

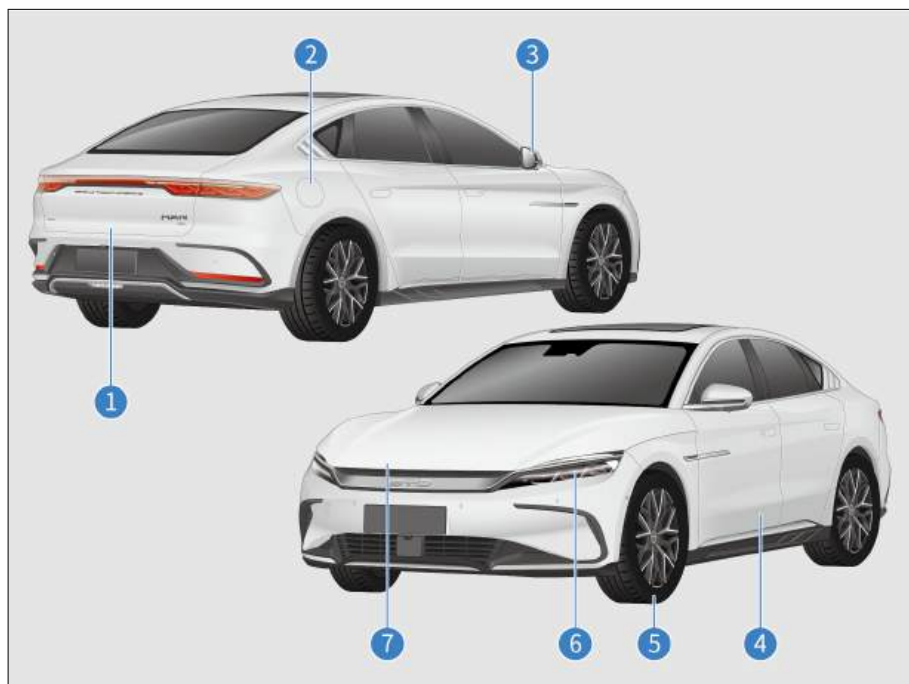

- | | | | |
|---|--|---|--|
| 1 | Trunk Lid P51
Carrying Luggage P97 | 5 | Tire P175
Snow Chains P138
If a Tire Goes Flat P177 |
| 2 | Using Mode 2 Charging Cable* P82
Using AC Charging Piles* P85
Using DC Charging Piles* P86
External Discharging Method* P90 | 6 | Combination Light P64 |
| 3 | Power Side Mirrors P137
Folding Side Mirrors P137 | 7 | Hood P172
Coolant P172
Washer P173
Braking System P173
Under-Hood Fuse Box P179 |
| 4 | Door P48 | | |

Dashboard

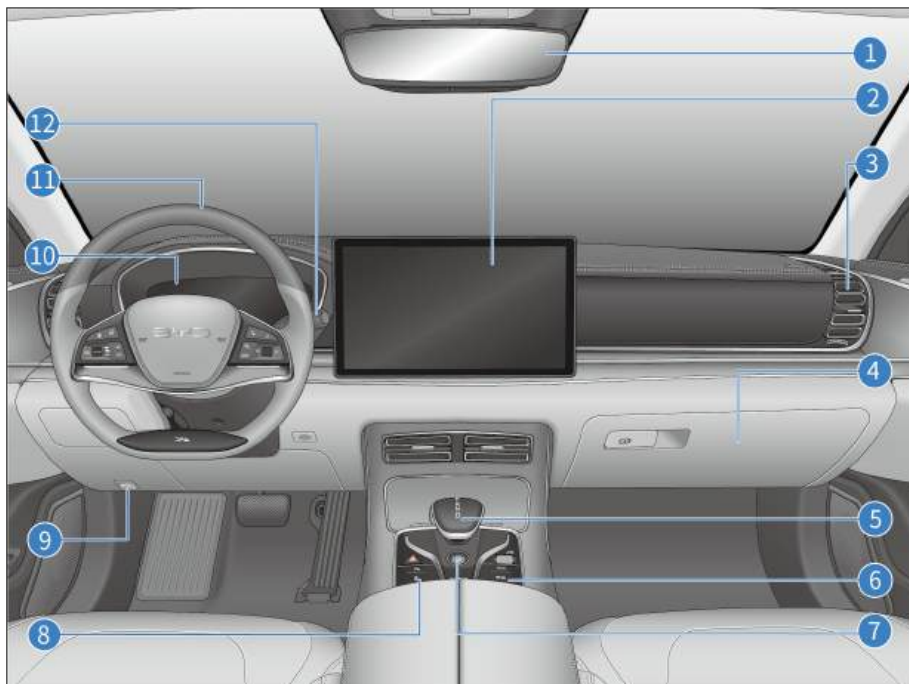

- | | | | |
|---|--|----|--|
| 1 | Interior Rearview Mirror P136 | 7 | START/STOP Button P99 |
| 2 | Infotainment Touchscreen P142
A/C Operation Interface P145
Air Purification System P150 | 8 | Parking Radar Switch P129
ESC OFF Switch P132 |
| 3 | Vent P149 | 9 | Opening the Hood P172 |
| 4 | Glove Box P153 | 10 | Instrument Cluster P34 |
| 5 | Gear Shift Controls P101 | 11 | Steering Wheel P60 |
| 6 | A/C Buttons P144 | 12 | Wipers P68
Replacing Wiper Blades P138 |

Interior

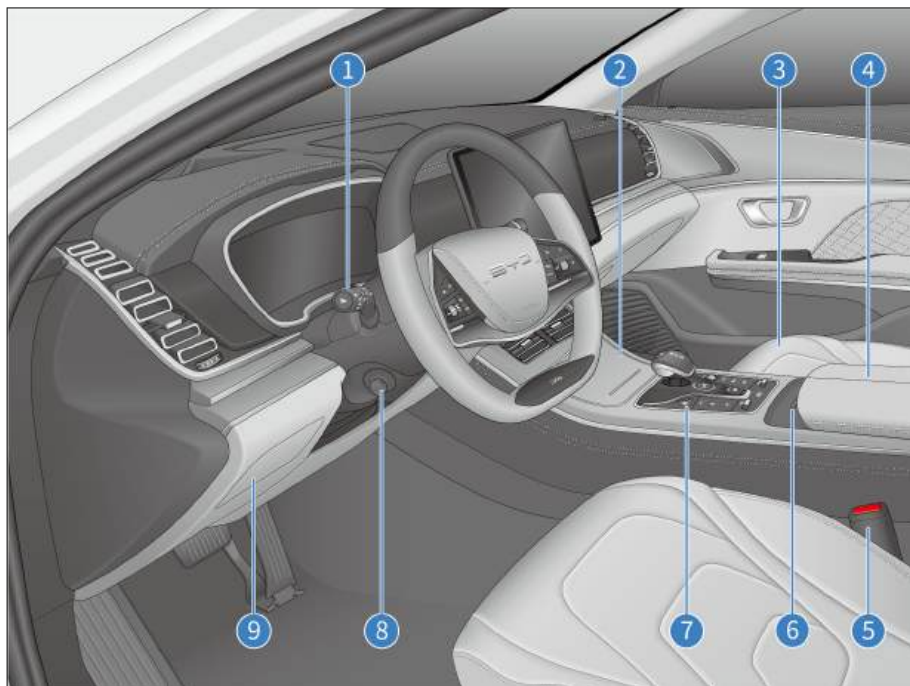

- | | | | |
|---|------------------------------------|---|---|
| 1 | Light Switches P64 | 7 | Hazard Warning Light P73 |
| 2 | Cup Holder P153 | 8 | Adjusting the Steering Wheel with Power* P62 |
| 3 | Seat P55 | | Adjusting the Steering Wheel Manually P63 |
| 4 | Center Console Cubby P153 | 9 | Bill Box P154 |
| 5 | Using Seat Belt P13 | | |
| 6 | Wireless Phone Charger P157 | | |

Doors

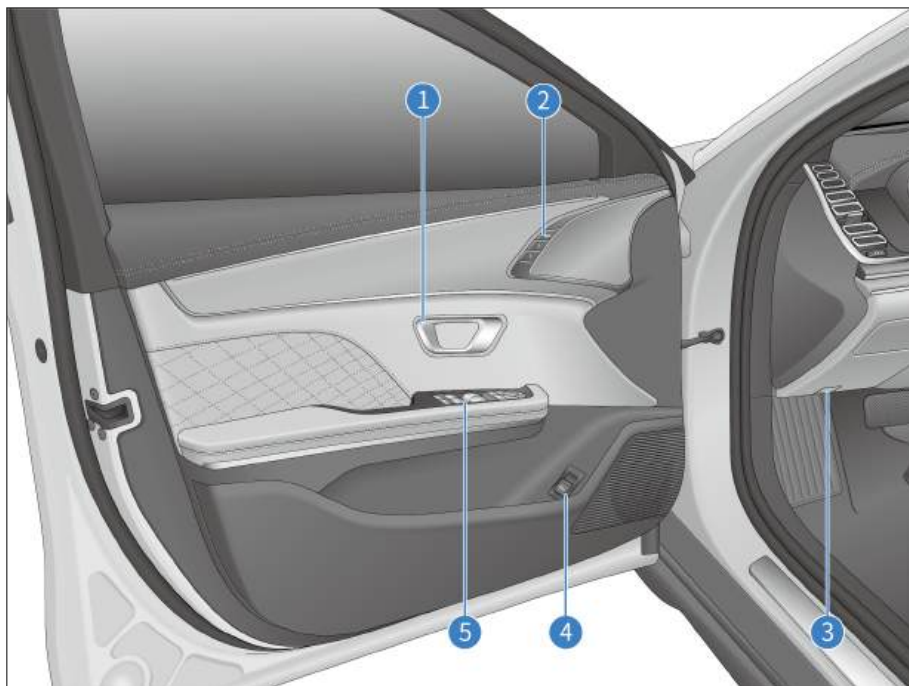

- | | | | |
|---|--|---|-----------------------------------|
| 1 | Opening with Interior Door Handle | 5 | Driver's Door Switches P69 |
| 2 | Memory System of the Seat P57 | | Central Locking P71 |
| 3 | Opening the Hood P172 | | Child Protection Locks P55 |
| 4 | Opening the Trunk from the Inside P51 | | |

01

SAFETY

Seat Belts.....	12
Airbags.....	15
Child Restraint Systems.....	23
Anti-theft Alarm System*	27
Data Collection and Processing.....	28

Seat Belts

Seat Belt Overview

Studies have shown that proper use of seat belts can significantly reduce casualties in emergency braking, sudden steering or collisions. Please read the following information carefully and observe it strictly.

CAUTION

- Always have the seat belts fastened while the vehicle is in motion.
 - Before driving, make sure all occupants are properly buckled up to prevent serious injury or death in emergency braking or in a collision.
 - The seat belts are designed primarily for adults and are not intended for children. Make sure to choose an appropriate child restraint system according to your child's age and size (see **P24**).
 - If a seat belt is damaged or malfunctions, immediately contact a BYD authorized dealer or service provider for confirmation and handling. Until then, do not use the corresponding seat.
-
- BYD has highly emphasized that all occupants should always fasten their seat belts while in the vehicle. Failure to do so increases the risk of injury in case of an accident.
 - It is recommended that children be seated in rear seats and always use seat belts and suitable child restraints. In emergency braking or collision, unprotected children may be seriously injured and their lives may

be endangered. Likewise, do not allow children to ride on someone's lap. This will render the children not adequately protected.

Emergency Locking Retractor Function

- When the driver turns sharply or brakes suddenly, when there is a collision, or when the occupant leans forward too quickly, the seat belt automatically locks to effectively restrain and protect the occupant.
- When the vehicle travels smoothly, seat belts are pulled out and retracted as the occupants move slowly and smoothly, allowing the occupants to move freely.
- If the seat belt locks due to sudden retraction, pull on the seat belt webbing to create retractable slack in order to pull out the seat belt.

Pretensioner and Force Limiter Function*

When a severe front collision occurs and the triggering conditions of the pretensioner are met, the pretensioner quickly retracts part of the seat belt and locks it to improve the protection of the occupant. The force limiter limits the seat-belt restraint force to the occupant's body to a certain extent so as to avoid injury to the occupant due to an excessive restraint force.

Seat Belt Pretensioning by Motor*

The seat belt automatically retracts in a hazardous situation to effectively secure the driver and passengers, and automatically returns to its relaxed state after the hazardous situation is resolved.

Webbing pretensioning

After the vehicle is started and the occupants fasten their seat belts, the

motor drives the webbing to retract to reduce the possible excessive slack of seat belts.

REMINDER

- Do not pull out the belt webbing forcibly during motor start-up, otherwise the motor will not disengage. If that happens, pull out the webbing with a greater force and insert the buckle for pretensioning.
- After the motor performs seat belt pretensioning, adjust the seat belt if it is too tight.

High-speed pretensioning

In case of emergency braking in situations such as urgent avoidance, front collision, rear collision, side collision, the motor is activated in advance to retract the webbing in a pre-tensioning manner to minimize the impact damage to occupants.

REMINDER

- If the seat belt cannot be released, move the seatback slightly backwards until the tension of the seat belt decreases and the locking mechanism unlocks.

Using Seat Belts

1. Adjust the seat position and seatback angle (see **P56**).
2. Adjust the position of the three-point seat belt.
 - Keeping a proper sitting posture, pull the seat belt out so that it is diagonally across the chest. The belt should not go under the arm or across the back of the neck.

- Keep the lap section of the belt as close as possible to the hip and do not keep it on the waist.

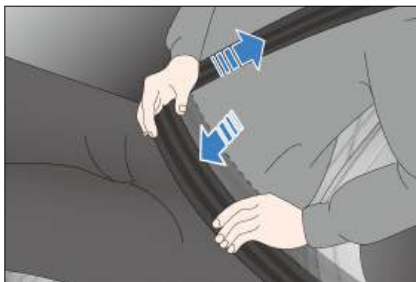

3. Insert the latch into the buckle until it clicks, and then pull it back to make sure it is firmly locked. Do not fasten the belt with any part of the strap twisted.

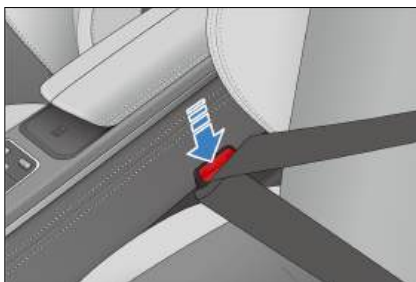

4. Adjust the height of the (front) seat belts for optimum comfort and protection.

- ① Press the adjuster release button.
- ② Move the adjuster up or down to the intended position and release it.

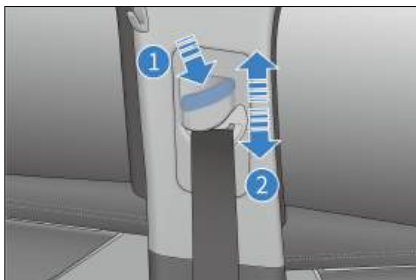

5. Pull the belt firmly to check that the adjuster is locked.

! WARNING

- The shoulder belt should cross the center of the shoulder. The seat belt should be far from the neck and not be liable to slip from the shoulder, otherwise, it cannot function well in the event of emergency braking or accident and may even cause severe injury.
- The lap belt should be positioned as low as possible around the hips to avoid serious injury due to the intense lap belt forces against the abdomen in an accident.
- The seat belt should be fitted tight to the body for better protection.

6. Unlock the seat belt.

- Press the red unlock button on the buckle. The latch plate pops out, and the seat belt automatically retracts.
- If the seat belt does not retract smoothly and automatically, pull it out and check whether it is twisted.



! WARNING

- Each seat belt can only be used by one occupant only at the same time. Do not share a seat belt with

! WARNING

another occupant, not even with a child.

- Avoid traveling with the seatback leaning too far back. The seat belt protection performs best when the seatback is upright.
- Make sure that no seat belt or its spring bolt/buckle becomes pressed by the door or rear seatback; otherwise, the seat belt may be damaged.
- Check the seat belts regularly, for cuts, wear, looseness, and other abnormalities. If any problem is found, contact a BYD authorized dealer or service provider for confirmation and handling. Until then, do not use the corresponding seat.
- Do not remove, disassemble or modify the seat belts without permission.
- After an accident, have the seat belts checked at a BYD authorized dealer or service provider. If the pretensioner function is activated, the seat belt must be replaced.
- Use an approved model whenever you replace the seat belt.
- In the event of a serious accident, even if there is no apparent damage, the seat belt should be replaced along with the seat assembly. The airbag system should also be thoroughly inspected.
- Pregnant women should also fasten the seat belt properly as other occupants, and pay special attention to the lap belt which should be positioned as low as possible around the hips to avoid

! WARNING

serious injury to them and their fetus due to the intense lap belt forces against the abdomen in an accident.

- The method of wearing a rear seat belt is the same as that for a front seat belt. For normal functioning of the rear seat belt, ensure that its latch is inserted into the corresponding buckle during use. The driver should remind passengers to wear seat belts properly.
- Do not insert foreign objects such as coins and clips into the buckle as they prevent proper connection between the latch and buckle.

Seat Belt Reminders

If any occupant has not buckled up after the vehicle is started, visual and audible alarms go off and continue until the corresponding seat belt is properly fastened.

- Seat belt reminder indicator
 - This indicator flashes if any seat belt is not fastened.
- Display of unfastened belt's seat
 - The indicator for the seat with unfastened seat belt lights up and is steady on in case of abnormal conditions in the vehicle.
- Seat belt reminder for front passenger
 - If the driver or front passenger has not buckled up after the ignition is switched on, the seat belt reminder indicator and the indicator associated with the corresponding seat light up. If the seat belt remains unfastened while driving, in addition to the reminder indicator, an audible

alarm is given to alert the driver and the occupant.

- Seat belt reminder for rear passengers
 - With the ignition on, if any rear-row seat belt is not fastened, the seat belt reminder indicator and the indicator associated with the corresponding seat light up.
 - While the vehicle is in motion, when only rear seats are loaded with occupant(s), who have not buckled up, the seat belt reminder indicator is on (some models) and an audible alarm is given.
- When the driver, the front passenger, and rear passengers have buckled up, the seat belt reminder indicator and all indicators displayed for the corresponding seats turn off.

! WARNING

- In the event of abnormality or function failure, contact a BYD authorized dealer or service provider. Do not use the corresponding seat until the functions return to normal.
- When driving, make sure all occupants have their seat belts properly fastened or in emergency braking or collision, passengers are more likely to be seriously injured and their lives may be endangered.

Airbags**Airbags**

- The airbag system is a part of auxiliary restraint system and also a supplement to seat belts. When the vehicle is involved in a serious

collision and the airbag system meets its deployment conditions, relevant airbags will rapidly deploy and, along with seat belts, provide additional protection for heads and chests of the occupants, to reduce likelihood of personal injury or even death.

- Airbags are divided into front and side types according to the type of collision. The front airbags include a front passenger airbag and a front passenger knee airbag, while the side airbags include seat side airbags and side curtain airbags.
- As an integral part of the vehicle's passive safety protection system, the airbag system does not replace seat belts, and must be used in combination with seat belts to maximize protection.

Multi-Collision Braking (MCB)

- If an accident requires front airbags activation, the vehicle will engage automatic braking.
- Speed reduction, along with intervention by additional driving systems (Electronic Stability Control (ESC), Anti-lock Braking System (ABS)), will assist the vehicle to maintain stability and lane position.
- Hazard and brake lights will also light up to alert oncoming traffic and prevent further collisions.
- To support emergency service rescue and vehicle recovery, brakes will release and brake lights will go off after the accident.
- The driver can interrupt the multi-collision braking at any time by accelerating or braking.

WARNING

- Occupants must sit in a proper position to maximize the

WARNING

protection provided by seat belts and the airbag system.

- Do not disassemble or assemble airbag components without authorization.
- Do not use seat covers, as they restrict airbag deployment on the corresponding side in an accident.
- Do not place anything between the side airbag and the occupant.
- Do not apply excessive force to the side of seats equipped with side airbags.
- After a collision, even if the airbag module did not deploy, and the pretensioner did not lock the seat belt, the airbag computer may be encrypted in order to protect occupants from high-voltage danger. Contact a BYD authorized dealer or service provider for inspection.

Driver and Front Passenger Airbags

This vehicle is equipped with driver and front passenger airbags, when the airbag system Electronic Control Unit (ECU) detects a moderate to severe front impact during driving and the triggering conditions are met, the airbags deploy to minimize the injury.

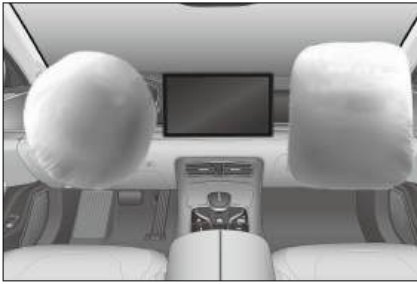

Front airbag deployment

- In moderate to severe frontal crashes, a sensor detects a sharp deceleration and sends a signal to the ECU to trigger the front airbags.
- When there is a frontal crash, the seat belt secures the occupant's lower body and torso in place. The airbag cushions and protects the occupant's head and chest.
- When the severity of the impact does not reach the airbag deployment threshold, seat belts provide enough protection.
- The front airbag deflates immediately after inflation, without affecting the driver's vision and ability to operate the steering wheel or other controls.
- The airbag deploys within a thousandth of a second to further protect drivers and occupants in an accident.
- A loud noise will be heard when the airbag deploys. It will not cause injury, but it may cause tinnitus or temporary deafness.
- A cloud of dust from the airbag surface may come off when the airbag deploys. Although such powder is non-toxic, individuals with respiratory problem might experience some temporary discomfort.

Knee Airbags

If the vehicle you purchased is equipped with a knee airbag (located inside the lower trim of the dashboard), when the electronic control unit (ECU) of the airbag system detects a moderate to severe front impact during vehicle travel and the triggering conditions are met, the knee airbag will deploy to help protect the legs and knees of occupants.



Seat Side Airbags

If the vehicle is equipped with seat side airbags (mounted on the outside of seatback, marked with "AIRBAG" at both sides), When a moderate to severe side impact is detected during vehicle travel and the triggering conditions are met, the side airbag deploys to protect the occupant's chest.

Front side airbags



Rear side airbag



CAUTION

- If the seatbacks get wet from rain or splashes, the side airbag system may not work properly.
- Do not cover or replace seatback covers on your own. Unsuitable seatback covers may prevent airbag deployment.

REMINDER

- In the event of a side impact, the airbag on the impacted side deploys when the airbag system meets its deployment conditions.
- For optimal side airbag protection, occupants must have their seat belts fastened and sit upright against the seatback.

Side Curtain Airbags

- The vehicle is equipped with left and right-side curtain airbags (mounted at the joint between the side walls of the body and the ceiling, with the A-pillar, B-pillar, and C-pillar shields marked with "AIRBAG", as shown in the illustration).



- When a moderate to severe side impact is detected during vehicle travel and the triggering conditions are met, the side curtain airbag deploys to protect the head of the occupant on the side of collision.
- Generally, only the airbag on the impacted side deploys in the event of a side impact.
- For optimum curtain airbag protection, the occupant must have their seat belt fastened and sit upright against the seatback.

Airbag Triggering Conditions and Precautions

Airbag Triggering Conditions

- Airbag triggering conditions: In the event of a vehicle collision, whether an airbag will be triggered is decided by factors such as the amount of collision energy, accident type, collision angle, obstacles and vehicle speed. The airbag system may be triggered in special collisions.
- The airbag system does not always work in any accident, and generally it will not be triggered in the event of a minor frontal collision, rear collision or rollover. In this case, the driver and passengers are protected by their properly fastened seat belts.

- Determinants of airbag system triggering: Decision is made by comparing the deceleration curve, generated in the collision and obtained by the ECU, and the set value. If signals, such as the deceleration curve generated and measured in the collision, are lower than the respective reference values preset in the ECU, the airbag system will not be triggered even if the vehicle may have been seriously deformed in the accident.
- The ECU of the BYD airbag system has been set up with considerations of common misuse and road conditions. However, due to the increasing changes in causes and forms of vehicle collisions, for your safety, please strictly follow this user manual, use the vehicle correctly, and avoid its misuse. Otherwise, there is no guarantee that the airbags will achieve their expected effect.

Cases When Airbags May Be Deployed

The vehicle's nose hits the ground when crossing a deep groove.



The vehicle hits a bump or curbstone.

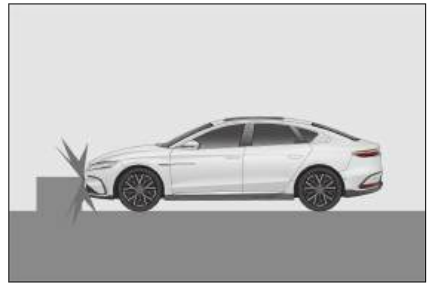

The vehicle's nose hits the ground when going down a steep slope.

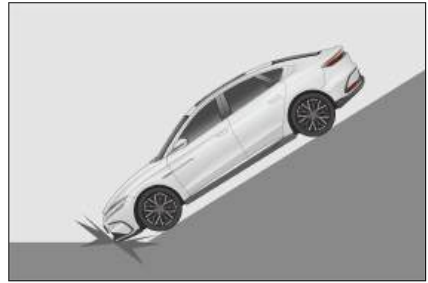

One side of the vehicle is hit by another vehicle.

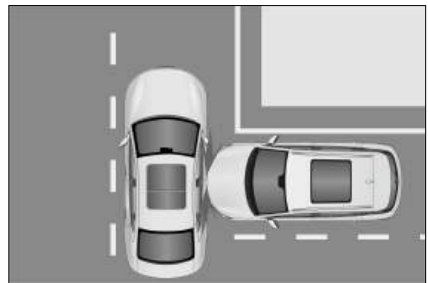

Cases When Airbags May Not Be Deployed

The vehicle hits a concrete column, tree, or other slim objects.

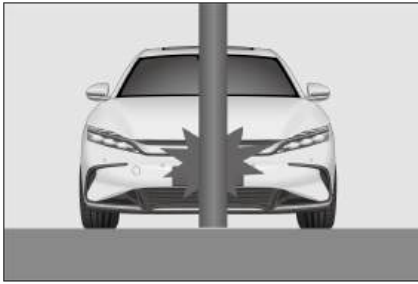

The vehicle goes under a truck or another large vehicle.



The vehicle hits a wall or a vehicle at a side other than the front side.



The tail of the vehicle is hit by another vehicle.



Parts other than the passenger compartment receive side impact.

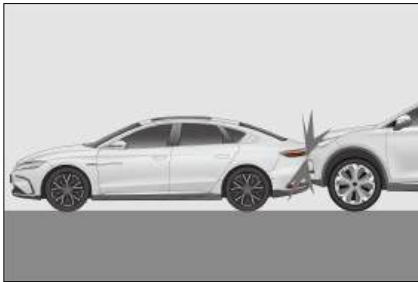

The vehicle rolls over.

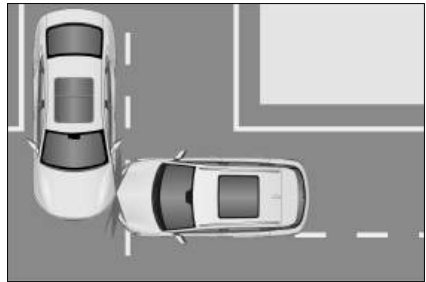

The lateral side of the vehicle is hit diagonally.

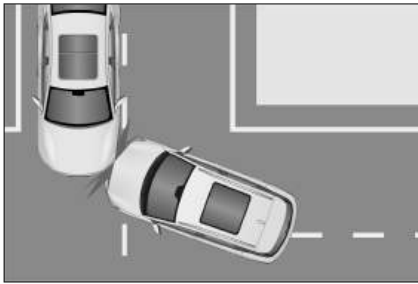

The lateral side of the vehicle hits a columnar object.



! WARNING

- Airbags are designed for specific models. Any changes to suspension, tire size, bumpers, chassis and factory-equipped devices may adversely affect the airbag system. Users must not use any parts of the airbag system on other car models; doing so may lead to failure of the airbag system.
- Drivers should maintain a distance of at least 25 cm between their chest and the steering wheel, in order for the system to provide the most effective driver protection.
- Fasten your seat belt and sit properly while the vehicle is in motion. If the seat belt is not fastened, if the occupant

! WARNING

is leaning forward or sitting improperly, airbag deployment can increase the risk of injury.

- Do not paste stickers, cover or decorate the hub cover of the steering wheel, the right side surface of the dashboard or the surface of A, B, and C-pillar trims. Clean these surfaces with a dry or damp cloth, without applying too much pressure.
- A child is not to be seated in the front passenger seat, nor are they to ride sitting on a front passenger's lap, to prevent serious injury or even casualty caused by airbag deployment.
- No accessories, such as telephone holders, cups, ashtrays, may be installed on airbag covers or within their action range. Otherwise, airbag deployment will increase the risk of injury in an accident.
- Side airbags and side curtain airbags deploy quickly with high impact forces. Occupants must not lean against the doors of vehicles equipped with these airbags while these vehicles are in motion. Failure to do so could result in serious injury or even death.
- Do not place any other accessories or items within the action range of side curtain airbags, including the windshield, side door glass, A-pillar trim, ceiling, B-pillar trim, C-pillar trim and auxiliary handles. When the side curtain airbag deploys, the accessories or items will be thrown by the impact force from the side air curtain airbag,

 **WARNING**

or the side curtain airbag may not deploy normally, resulting in serious injury or even death.

- When transferring car ownership, make sure to pass on all of the vehicle's documents.
- Do not modify or replace seats or trims of the seats with side airbags. These changes may prevent normal deployment of side airbags, and thereby cause airbag system failure or unintended deployment of side airbags, resulting in serious injury or death.
- Do not disassemble or repair the A-pillar trim, ceiling, B-pillar trim or C-pillar trim, which contain side curtain airbags. These changes can cause failure of the airbag system or accidental deployment of curtain airbags, which may cause serious injury or even death.
- Do not change any component of the airbag system, including any corresponding label. It is recommended that any operation done to the airbags be performed by a BYD authorized dealer or service provider.
- Airbags can only provide one-time accident protection. Once the airbag is triggered or damaged, the airbag system must be replaced.
- Follow safety regulations and procedures related to the scrapping of parts of the vehicle or its airbag system.
- The airbag system has strong anti-interference and anti-disturbance

 **WARNING**

resistance to electromagnetic fields around it. However, to avoid accidents, do not use the vehicle in an electromagnetic environment that violates national regulations.

- The airbag system of this vehicle is designed with full consideration of domestic common misuses and road conditions. However, in order to avoid accidents, do not have the bottom of the vehicle impacted or drive roughly in harsh road conditions.
- This vehicle's airbag system has been fully verified to seamlessly match the vehicle's original wiring harness system. Any wiring harness modification or alteration may cause the airbags to deploy mistakenly under normal conditions or fail to deploy in the event of a collision.

It is recommended that you contact a BYD authorized dealer or service provider immediately if any of the following situations occurs.

- The airbag has deployed.
- Instrument cluster airbags warning light  lights up abnormally.
- There is a collision with the front of the vehicle (highlighted area shown), but the front airbags do not deploy.

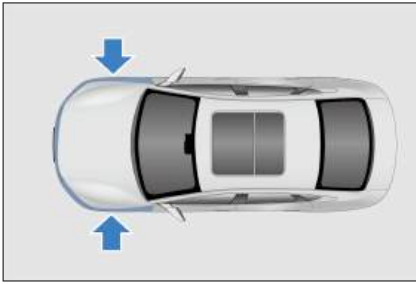

- The airbag cover has been scratched, cracked or otherwise damaged.

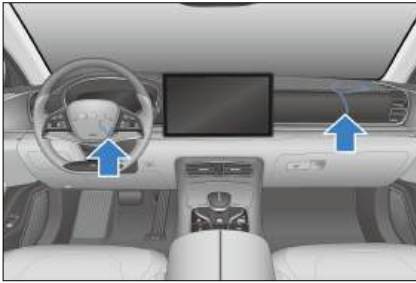

- Airbags need to be removed, disassembled, installed or repaired.
- Side airbags and curtain airbags have deployed.

Recommended child restraint systems:

Weight Group	Child Weight	Child Restraint System	Type
Group 0	less than 10 kg	-	-
Group 0+	less than 13 kg	Maxi Cosi Cabriofix	Universal class
Group I	9-18 kg	Britax Römer King II LS	Universal class
Group II	15-25 kg	Britax Römer KidFix ² S	Universal class Semi-universal class
Group III	22-36 kg	Britax Römer KidFix ² S	Universal class Semi-universal class

① Group 0+

② Group I

- An impact to a vehicle door in an accident is not adequate to cause the airbag to deploy.
- The surface of the seat with a side airbag is scratched, cracked, or damaged similarly.
- Decorative (liner) parts at A-pillar with built-in curtain airbags, roof beam and C-pillar are scratched, cracked, or damaged similarly.

Child Restraint Systems

Child Restraint Systems

- Child restraint systems provide good protection to your child in an accident. For the child's safety, please carefully read the instructions provided with the child restraint and in this manual before installing a child restraint.
- Choose a suitable child restraint system for your child's age and stature.

③ Group II / Group III



- Children must use a suitable child restraint when traveling in the vehicle. Children should sit comfortably and safely. Make sure that the child restraint is positioned, mounted, and used correctly.
- If the child is too large to use a high-back child restraint, please sit in the rear outboard seat and follow the installation instructions provided by child restraint manufacturer to use the booster chair attached to the lower anchoring device, or use the seat belt.

⚠ WARNING

- Never carry a child on your lap in a vehicle journey.
- An appropriate child restraint system must be used for your child.
- Please follow the instructions provided with the child restraint system and in this manual to make sure the child restraint is properly installed in the vehicle.
- After the child restraint is dismantled from the seat, store it safely in your trunk.
- Failure to follow the instruction provided with the child restraint and in this manual may cause injuries and even death to your child in an accident.

- Secure the top tether when installing the child restraint system.

Installing Child Restraint Systems

Follow the installation instructions provided by the child restraint manufacturer. Secure the child restraints to the rear outboard seats.

Installing Child Restraint Systems with ISOFIX Rigid Anchor

A special anchorage is provided on the rear outboard seat, and it can be seen after its decorative cover is opened (the label showing the anchorage is attached to the seat).



Anchor supports (for the top tether) are provided at the rear outboard seat.

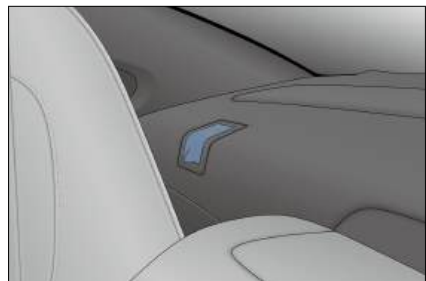

! REMINDER

- Secure the top tether when installing the child restraint system.

- Installing child restraint systems:

1. Open the anchorage lever trim cover and install the child restraint system to the seat.

**! WARNING**

- When using the lower anchoring device, make sure that no foreign objects are around the anchoring device and that the seat belt is not stuck behind the child restraint; make sure that the child restraint is securely fixed, otherwise emergency parking or an accident may result in serious even fatal injury to a child.
- Do not install a child restraint on the front passenger seat.

! REMINDER

- The anchorage lever is located on the bevel at the rear end of the seat cushion and is visible by flipping the anchorage lever trim cover open.

2. Lift the head support and open the anchor support cover.

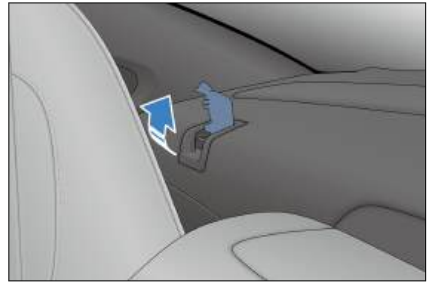

3. Fasten the snap hook to the anchor support and tighten the top tether to ensure the strap is buckled securely.

- ① Top tether
- ② Anchor support
- ③ Snap hook

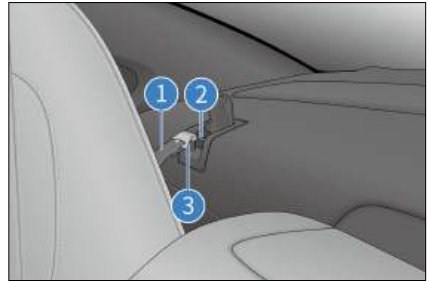
**! WARNING**

- Push/Pull the child restraint in different directions to ensure it is securely installed.

! REMINDER

- If the CRS is equipped with a top tether, secure the tether to the anchoring device.
- If the driver seat obstructs the correct installation of the child restraint, install it on the right-hand seat of the second row.

- Never install a rear-facing child restraint on the seat protected by a front airbag (in the active state), otherwise in the event of an accident, the force of rapid deployment of the front passenger airbag will result in death or serious injury to the child.



Recommended seating positions for installing child restraint systems

Weight Group	Seat (or Other Positions)		
	Front Passenger Seat	Rear Outboard Seat	Rear Middle Seat
Group 0 (up to 10 kg)	X	U	X
Group 0+ (up to 13 kg)	X	U	X
Group 1 (9-18 kg)	X	U/UF	X
Group 2 (15-25 kg)	X	UF	X
Group 3 (22-36 kg)	X	UF	X

Note: Table definitions:

U: seat suitable for installing a universal child restraint certified for this weight group

UF: seat suitable for installing a front-facing universal child restraint certified for this weight group

X: seat position not suitable for installing a child restraint for this weight group

Suitability of ISOFIX seating positions for ISOFIX child restraint systems:

Weight Group	Size	Fixed Module	Seat (or Other Positions)		
			Front Passenger Seat	Rear Outboard Seat	Rear Middle Seat
Carrycot	F	ISO/L1	X	X	X

Weight Group	Size	Fixed Module	Seat (or Other Positions)		
			Front Passenger Seat	Rear Outboard Seat	Rear Middle Seat
Group 0 (up to 10 kg)	G	ISO/L2	X	X	X
	E	ISO/R1	X	X	X
Group 0+ (up to 13 kg)	E	ISO/R1	X	X	X
	D	ISO/R2	X	X	X
	C	ISO/R3	X	X	X
Group 1 (9-18 kg)	D	ISO/R2	X	X	X
	C	ISO/R3	X	X	X
	B	ISO/F2	X	IUF	X
	B1	ISO/F2X	X	IUF	X
	A	ISO/F3	X	IUF	X

Note 1: For child restraint systems not identified with ISO/XX size classes (A-G), the vehicle manufacturer shall specify the in-vehicle ISOFIX child restraint systems recommended for each seating position with respect to their applicable weight groups.

Table definitions:

IUF: seat position suitable for installing a front-facing universal ISOFIX child restraint certified for this weight group

X: ISOFIX seating position not suitable for installing an ISOFIX child restraint for this weight group and/or this size class

Anti-theft Alarm System*

Anti-theft Alarm System*

When armed, the system sounds an alarm and triggers turn signal flashes when any door is opened.



Arming the system

1. Switch the ignition off.

2. All occupants get off the vehicle.
3. Lock all doors. This makes the anti-theft indicator steady on. The anti-theft alarm system will arm automatically after 10 seconds, and the anti-theft indicator will then begin to flash.
4. You can leave the vehicle after confirming that the indicator begins to flash. Since unlocking the door from inside the vehicle will activate the system, never let anyone stay in the vehicle with the system enabled.

Triggering the alarm

- The system will raise an alarm in any of the following situations:
 - Any door, trunk, or hood is opened without using the keyless access function of the smart key.
 - The vehicle is powered on without using the smart key start function.

Disarming the system

- Anti-theft alarm can be stopped by:
 - Unlocking the door with a valid smart key.
 - Using the microswitch to unlock the door by carrying a valid smart key.
 - Opening the trunk remotely with a valid smart key.
 - Starting the vehicle remotely with a valid smart key.
 - Pressing the START/STOP button inside the vehicle while carrying a valid smart key.

WARNING

- Do not modify the anti-theft alarm system by means of alteration or addition. Otherwise, the system may fail.

Anti-theft Indicator*

When the alarm is armed, the anti-theft indicator is solid on for about 10 seconds.



Data Collection and Processing

Data Collection and Processing

- This section provides you with some important information on how personal data is collected and processed when you use a BYD vehicle.
- For a more detailed overview on data processing, data protection and data subject rights, please read the current version of the privacy policy for the vehicle available at the infotainment system (**System** → **More** → **BYD Vehicle System Privacy Statement**).
- This vehicle is equipped with an event data recording (Event Data Recorder(EDR)) system. EDR mainly records data in the event of a crash or near-crash (for example, airbag deployment or hitting on a roadside obstacle) to help comprehend the vehicle system operation, such as:
 - Vehicle velocity
 - Tire pressure condition

- Adaptive cruise control (ACC) system status
- Whether the seat belt is fastened
- The vehicle records EDR data only when there is a crash or when a near-crash event reaches a certain extent. The EDR does not record any data during the normal driving of the vehicle.
- The data recorded by the EDR system provides an understanding of the state of the vehicle's safety-related systems when an accident occurs, so that relevant parties can analyze the accident.
- The EDR data needs to be accessed and read by special equipment. BYD discloses your personal data to third parties only if this is legally permissible or you have consented to it. In addition to the vehicle manufacturer, third-party agencies with professional equipment (such as government agencies) can also read the EDR data if they have access to the vehicle EDR and equipment (for example, they can read the data of SRS control unit to clarify the accident).

Vehicle Data Processing

- Data is collected when the vehicle is used, such as data collected or transmitted by vehicle sensors or control units, which is necessary for the safe functioning of your vehicle.
- In some cases, the data is used to support driving (driver assistance systems) or to enable a specific comfort or infotainment function.
- Personal data that is collected and processed mainly include in-vehicle data, remote-services-related data, and other data, as further specified below.

In-vehicle data

Operation data

- When the vehicle is used, various vehicle status data (e.g., speed, battery level, and braking system) or environment (e.g., distance sensors, rain sensor, and temperature) data is collected and processed.
- This data is not usually stored, but there are control units, sensors or other components installed in the vehicle that record such data, for example, to record maintenance requirements, error messages, or other information.
- The in-vehicle data will only be stored in the equipment in the vehicle but can be read out via the legally required OBD ("On Board Diagnostics") interface, for example, by BYD authorized dealer or service provider or other third parties.
- In case this access takes place during vehicle maintenance, the information can also be transmitted to BYD engineers for quality assurance, product defect reports, or customer claim verification.

Remote-services-related data

Remote monitoring services

- The vehicle has remote monitoring services. These include remote diagnosis and over-the-air (OTA) updates and upgrades for security and safety purposes (subject to owner's approval).
- These monitoring services serve the following purposes: service provision (remote support/diagnostics), product development, and security/public safety.
- Depending on the country and setup, various vehicle information can be transmitted to the data center of BYD

in corresponding market for the above purposes, including vehicle location information, vehicle status, such as energy consumption, vehicle speed, gear position, power mode, ESC status, steering system status, battery status, powertrain status, and overall vehicle performance status.

Other

Infotainment system

- Depending on vehicle configuration, data can be added to the infotainment system by the users themselves, such as media data for playing video on the infotainment system, address data for use in the navigation system, or data for use in online services.
- Depending on vehicle configuration, individual settings in and on the vehicle can also be entered.
- Data stored in the vehicle can be deleted at any time.
- BYD has no control over data transferred to third parties (from the use of third party content, in particular as part of online services).

Integration of mobile devices

- Depending on vehicle configurations, mobile devices can be connected and controlled through the vehicle's infotainment system.
- It may be necessary that the device's screen or audio is displayed/played through the infotainment system or transmitted to it.
- Additional data like positioning or vehicle information can be transmitted through applications for use in certain navigation systems, communication, or other third-party services.
- The specific type of data processing depends on the respective function and is controlled by the user or third

parties such as the provider of the devices or corresponding services.

Internet access and connected services



- Depending on vehicle configurations, the Internet can be accessed for certain functions or BYD services through the vehicle's infotainment system network devices.
- BYD is not liable for any such services provided by any other party.
- In such cases, please obtain information about the use of data from the provider of the respective online service.

Camera image recording/surrounding area monitoring

- Your vehicle is equipped with a number of cameras/sensors.
- The reason for this is that some vehicle functionalities require the vehicle's path to be detected and assessed which is done by cameras that detect objects in the vehicle's surroundings (e.g., obstacles).
- The images are transmitted to the respective control module for further analytics required to operate the systems.
- Some images are just processed on a volatile basis (RAM), others may be stored, depending on vehicle equipment.
- The vehicle may be equipped with an outward-facing camera (OFC) that can be used to take footage of the surrounding (for example, dashcam).
- The vehicle may also be equipped with an inward-facing camera (IFC), which can be used to take footage inside the vehicle.
- Both OFC and IFC footage is stored.

- You are responsible to check the laws of your residence before turning on your OFC or IFC (for instance, in some countries consent is required for the use of IFC, and in others OFC is strictly restricted to dashcam purposes).
- For more camera details, see **P29**.

Permanent Vehicle Transfer to Third Parties and Offline Mode

- In case of a permanent vehicle transfer, i.e., second hand vehicle, or vehicle transfer by a third party for permanent use, it must be noted that any personalization/user settings made via the infotainment system (e.g. address list, navigation system, etc.) can be accessed by the new owner.
- You can also restrict your vehicle's communication with the BYD data server and the processing of vehicle-related and personal data by setting the vehicle to offline mode.
- On the infotainment touchscreen, tap  to turn Wi-Fi off.
- This can also be done by tapping  → **System Settings** → **Internet** → **WLAN** → **Off**.

Disclosure of Personal Data to Authorities

- BYD will not disclose your personal data to third parties unless this is legally permissible or you have consented to it.
- However, subject to applicable laws, government agencies may be authorized to read out data from vehicles (for example, data can be read from the airbag control unit to clarify an accident).

- If required by law, BYD may also be obliged to disclose data upon request to governmental authorities in your country/region, such as in the investigation of a criminal offence.

Your Data Protection Rights

- BYD has staunch respect for its customer's privacy, and strictly complies with all data protection laws, in particular the General Data Protection Regulation (GDPR) and applicable local laws.
- According to these laws, owners have specific rights when their personal data is processed:
 - Data subjects have the right of information and access, to rectification, erasure of personal data ("right to be forgotten") and the right to object to the processing of personal data or to restrict it (or to withdraw consent given earlier, as well as the right to data portability).
- These rights may be limited in some cases. For example, if we can show that we have a legal obligation to process your data, or if providing the information to you would disclose personal data about another person, or if we are legally prevented from disclosing that information.
- In some cases, this may mean that we can retain the data even if you withdraw your consent.
- For more information on data processing, data protection, and any rights you may have, please visit the latest version of the Privacy Policy available at the infotainment system (**Vehicle** → **System** → **More** → **Privacy Policy**).

02

INSTRUMENT CLUSTER

Instrument Cluster.....34

Instrument Cluster

Instrument Cluster View

Instrument Cluster



1 Power meter

2 Time

3 Gear status

4 Outside temperature

5 Speedometer

6 Total mileage

7 Remaining driving range

8 State of charge (SOC)

Figure 1: Instrument cluster view in simple mode

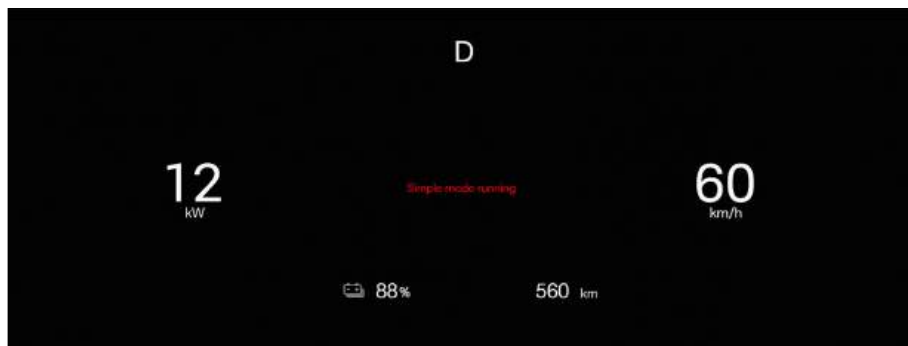

 CAUTION

- During occasional communication delays in the instrument cluster system, the instrument cluster may automatically switch to simple mode for safe driving. In this mode, the instrument cluster continues to display driving related information normally without affecting normal vehicle travel. After the system becomes normal, the instrument cluster may automatically exit the simple mode. If it does not, try the following actions to switch back to normal mode:
 1. Press and hold the scroll button on auxiliary dashboard for three seconds to restart the instrument cluster information display system.
 2. While vehicle safety is ensured, operate the vehicle power

 CAUTION

- switch to turn off the vehicle and then turn the ignition on.
- If the instrument cluster remains in simple mode after those actions have been taken, promptly contact a BYD authorized dealer or service provider for inspection.
- The image of the instrument cluster view is for reference only and is subject to actual factory configuration.

Instrument Cluster Indicators



























Indicators/Warning Lights





















Turn signal indicator



Position light indicator

	High beam indicator		HMA indicator*
	ICC indicator		Front fog light indicator*
	AVH indicator		Hill descend control indicator
	Exterior light switch indicator		AVH standby indicator
	Discharge indicator		OK indicator
	Economic mode		ACC speed indicator
	Sport mode		PCW indicator (green)
	Normal mode		AEB warning light
	High-voltage battery low SOC warning light		Rear fog light indicator
	Driver monitoring system fault indicator		Smart key warning light
	Tire pressure fault warning light		Main alarm indicator
	ESC OFF warning light		Headlight fault warning light
	ESC fault warning light		Driving power limit warning light

	ABS fault warning light		Snow mode indicator
	BSD indicator*		AVAS OFF indicator
	PCW warning light (red)		High-voltage battery overheating warning light
	Motor overheating warning light		Low-voltage power system fault warning light
	Powertrain fault warning light		Door status indicator
	TSR indicator		Motor coolant overheating indicator
	Seat belt reminder indicator		Airbag fault warning light
	EPB indicator		Parking system fault warning light
	Steering system fault warning light		Anti-theft Indicator
	High-voltage battery fault warning light		High-voltage battery charging connection indicator

Warning Light/Indicator Description

Smart key warning light

- If the key is not in the vehicle when you press the START/STOP button, this warning light comes on for a few seconds, a beep sounds, and the message "No key detected, please confirm if the key is in the vehicle" is displayed on the instrument cluster.

- If you press the START/STOP button while an electronic smart key matching the model is in the vehicle, this warning light does not light up. The vehicle can now be powered on.
- If the warning light flashes after you press the START/STOP button, it indicates low battery of the key.
- If the key is not in the vehicle, the instrument cluster prompts "No key detected, please confirm if the key is in the vehicle".

ABS fault warning light

- This warning light comes on when the ignition is on. If the anti-lock braking system (ABS) is working properly, the light goes out in a few seconds. Thereafter, if the system fails, the light lights up again until the fault is cleared.
- When the ABS fault warning light is on (with the parking system fault warning light off), the braking system continues to operate whereas the ABS does not.
- When the ABS fault warning light is on (with the parking system fault warning light off), since the ABS system does not operate, the wheels will be locked in case of emergency braking or braking on a slippery road.
- If any of the following cases occurs, it means there is a fault in components monitored by the warning light system. In that case, contact a BYD authorized dealer or service provider for vehicle inspection as soon as possible.
 - This warning light does not come on or is steady on when the ignition is on.
 - This warning light turns on during driving.

REMINDER

- A warning light that lights up briefly during operation does not indicate a problem.
- If the ABS fault warning light is still on while the braking system warning light is on, immediately park the vehicle in a safe place. It is recommended to contact a BYD authorized dealer or service provider. In this case, if brakes are applied, the ABS will not work and

REMINDER

the vehicle will become extremely unstable.

- If both ABS indicator and the braking system indicator come on and the electronic parking brake (EPB) is fully released, the braking force distribution system of front and rear wheels has also failed.

Tire pressure fault warning light

- This warning light comes on when the ignition is on. It turns off in a few seconds if the tire pressure monitoring system is working properly. If the system fails, this warning light turns on again.
- When the tire pressure fault warning light comes on or flashes, the message "Please check TPMS" is displayed on the instrument cluster, and the tire pressure is displayed as "---", it indicates that the tire pressure system is faulty.
- When the tire pressure value displays "No Signal", it indicates that the tire pressure signal at this location may be interfered or the tire pressure monitoring module is damaged.
- When the tire pressure fault warning light is solid on and one or more values turn yellow on the tire pressure screen on the instrument cluster, the corresponding tire is in under-pressure condition. When the temperature value of one or more tires turns yellow, it indicates that the tire temperature is too high.

In the event of any of the situations above, it is recommended to contact a BYD authorized dealer or service provider for inspection as soon as possible.



ESC warning light

- This warning light turns on after the vehicle is started. If electronic stability control (ESC) functions properly, the light goes out in a few seconds. If ESC is faulty, this light comes on again until the fault is cleared.
- If the ESC warning light flashes temporarily while the vehicle is in motion, it indicates the ESC system is working.
- When the ESC warning light turns on (with the ABS fault warning light and the parking system fault warning light off), the ESC fails, but the ABS and the braking system continue to operate normally.
- When the ESC warning light turns on (with the ABS fault warning light and the parking system fault warning light off), the ESC system does not work. This means the vehicle is extremely unstable at sharp turns or when the driver steers away from obstacles ahead.
- If any of the following cases occurs, it means there is a fault in components monitored by the warning light system. In that case, contact a BYD authorized dealer or service provider for vehicle inspection as soon as possible.
 - This warning light remains off (self-check not performed) after the vehicle is started.
 - This warning light is steady on while driving.



REMINDER

- A warning light that lights up briefly during operation does not indicate a problem.



REMINDER

- If the ESC warning light remains on while the warning lights for the ABS and the braking system are on, immediately stop the vehicle in a safe place and contact a BYD authorized dealer or service provider. This is because braking at this time can render the vehicle extremely unstable, and the anti-lock braking system does not work at all.



ESC OFF warning light

- When the ESC OFF switch is pressed, this warning light should remain steady on and the ESC system will not operate. When the ESC OFF switch is pressed again, this warning light should turn off and the ESC system resumes its normal operation.



REMINDER

- While the ESC OFF warning light is on, the driver must stay alert and keep driving at a lower speed when making a sharp turn and when avoiding an obstacle which appears suddenly, because braking at this time can render the vehicle unstable, given the malfunction of ESC system.



Driving power limit warning light

- When the level of the high-voltage battery is low and the motor power is limited, this warning light will light up, and it is recommended to contact a BYD authorized dealer or service provider immediately.



Main alarm indicator

- If this indicator goes on, check the fault prompt or warning on the instrument cluster.



Seat belt reminder indicator

- With the ignition switched on, if any passenger on the front seats or rear seats* has not buckled up, the seat belt reminder indicator lights up. The indicators will not go off until the seat belt is buckled.



Airbag fault warning light

- With the ignition switched on, this warning light turns on and then goes off in a few seconds if the airbag system is working properly. This warning light is used to monitor the airbag ECU, collision sensors, inflation device, warning lights, connections, and power supply.
- If any of the following cases occurs, it means there is a fault in components monitored by the warning light system. In that case, contact a BYD authorized dealer or service provider for vehicle inspection as soon as possible.
 - When the ignition is switched on, this warning light remains off or is solid on after the ignition is switched on.
 - This warning light turns on during driving.

Parking brake system fault warning light

- When the brake fluid level is low and the braking system is faulty, this warning light lights up. If any of the following conditions occurs, immediately park the vehicle in a safe place. It is recommended to contact a BYD authorized dealer or service provider.

- This warning light comes on when the ignition is switched on and the brake fluid level is low.



REMINDER

- When the brake fluid level is low, park the vehicle because it is dangerous to continue driving.
- This warning light is solid on although after starting the vehicle, the brake fluid level and EPB system operation are normal (the EPB is engaged and released normally, and the message "Please check the EPB" is not displayed).
- Fault warning lights for parking brake and ABS come on simultaneously.



REMINDER

- A warning light that lights up briefly during operation does not indicate a problem.



! Steering system fault warning light

- When the steering system is faulty, this warning light is steady on. It is recommended to bring the vehicle to a BYD authorized dealer or service provider for inspection.



REMINDER

- The steering system features an electric motor to reduce the force required to turn the steering wheel.
- When turning the steering wheel, a hum may be heard from the running motor. This does not indicate that the motor is faulty.
- Do not turn the steering wheel to its limit position for more

REMINDER

than five seconds, otherwise the temperature protection will be activated and the steering system will be damaged or steering will become heavy.

- If you have turned the steering wheel frequently with the vehicle staying put for a long time, the steering wheel may become difficult to turn even if the warning light does not turn on. This is not a fault.
- To prevent steering system overheating, the power assist effect will be reduced if the steering wheel has been frequently turned with the vehicle staying put for a long time. As a result, the steering wheel become difficult to turn. In this case, reduce steering frequency or power off the vehicle. The system will recover within 10 minutes.

WARNING

- If the steering system warning light goes on, immediately park the vehicle safely, and contact a BYD authorized dealer or service provider.



Low-voltage power system fault warning light

- If this warning light turns on while the vehicle is in motion, it indicates that there is a problem with the DC system or the low-voltage power system. Turn off devices such as the A/C, fan, and radio, and pull over the vehicle immediately if it is safe to do so. It is recommended to contact a BYD authorized dealer or service provider for rescue as soon as possible.

- Charging and discharging stop when this warning light turns on.
- When this warning light lights up and remain steady on while driving, the vehicle speed will be limited.
- This light is used to warn about the operating state of the DC module and the low-voltage battery module when the vehicle is not being charged or discharging.



Powertrain fault warning light

- If the powertrain fails, this warning light turns on.
- If any of the following cases occurs, it means there is a fault in components monitored by the warning light system. In that case, contact a BYD authorized dealer or service provider for vehicle inspection as soon as possible.
 - This warning light is steady on when the ignition is switched on.
 - This warning light turns on during driving.



CAUTION

- Try not to drive the vehicle when the warning light is on. Contact a BYD authorized dealer or service provider to check the problem as soon as possible.



High-voltage battery overheating warning light

- If this warning light is on, it indicates that the high-voltage battery temperature is too high and the vehicle must be stopped to cool down. When the warning light flashes, it is recommended to immediately stop the vehicle safely and leave the vehicle as soon as possible.

- The high-voltage battery may overheat under the following operating conditions:
 - Driving up a slope for a long time in hot weather.
 - Long period of stop-and-go traffic condition, frequent rapid acceleration, frequent hard braking, or vehicle running for a long time without pause.



High-voltage battery fault warning light

- This warning light comes on when the ignition has just been switched on. If the high-voltage battery system is working properly, this warning light will turn off in a few seconds. Thereafter, if the system fails, this light will light up again. It is recommended to contact a BYD authorized dealer or service provider for inspection as soon as possible.
- If any of the following cases occurs, it means that there are faults in the components monitored by the warning light system. In such case, it is recommended to contact a BYD authorized dealer or service provider for vehicle inspection as soon as possible.
 - This warning light is steady on when the ignition is on.
 - This warning light is steady on or occasionally turns on while driving.



PCW warning light (red)

- When this indicator is on or flashes, pay attention to the distance from the vehicle ahead, and do not get too close to it to prevent potential collision.



Door status indicator

- When any door, the trunk or the hood is not closed, the indicator indicates the vehicle body and corresponding status. When the vehicle speed exceeds a certain value, the message "Door, trunk or hood not closed" will be displayed.



Motor coolant overheating indicator

- When this indicator is steady on, it indicates that the coolant temperature is too high. In that case, stop to cool down the vehicle. When the indicator flashes, it indicates the coolant level is low. Add coolant promptly.









TSR indicator*

- When this indicator lights up, it means that the vehicle system has recognized the speed limit value on current road section.

Other Instrument Cluster Fault Prompts

The instrument cluster may display the following fault prompts. Handle them as recommended:

Symbol	Fault Prompt	Response
	Please check the OBC system	The on-board charging system is faulty. In this case, check the charging connection, and reconnect the charging equipment. If the fault

Symbol	Fault Prompt	Response
		persists, contact a BYD authorized dealer or service provider.
	Vehicle network error, please pull over safely and contact BYD service	The vehicle may be disconnected from the data network. In this case, park the vehicle immediately at a safe place, and contact a BYD authorized dealer or service provider.
	EV function limited	The EV function is limited. Contact a BYD authorized dealer or service provider immediately.
	Please check the headlamp system	The headlight is faulty. In this case, contact a BYD authorized dealer or service provider.
	ADAS is limited*	The predictive collision warning and automatic emergency braking systems are faulty. In this case, park the vehicle, and contact a BYD authorized dealer or service provider.
	ADAS is limited*	The blind spot assist system is faulty. In this case, park the vehicle, and contact a BYD authorized dealer or service provider.
	ADAS is limited*	The lane departure assist system is faulty. In this case, park the vehicle, and contact a BYD authorized dealer or service provider.
	Please check the multi-purpose camera	The function of the multi-purpose camera is limited. In this case, park the vehicle, and contact a BYD authorized dealer or service provider.
	Please check the gear*	The shifter controller is faulty. In this case, park the vehicle immediately, and contact a BYD authorized dealer or service provider.

03

CONTROLLER OPERATION

Doors and Keys.....	46
Seats.....	55
Steering Wheel.....	60
Switches.....	64

Doors and Keys

Keys

The vehicle is equipped with keys, including the electronic smart key and mechanical key (installed in the electronic smart key) to enable functions such as unlocking/locking doors and starting the vehicles.

Smart Key

Press the left or right front door microswitch, while carrying the smart key, to unlock or lock all doors, or press smart key buttons to lock/unlock doors, open the trunk, or start the vehicle remotely.

- ① Indicator
- ② Lock button
- ③ Unlock button
- ④ Trunk release button
- ⑤ Start/Stop button
- ⑥ Mechanical key

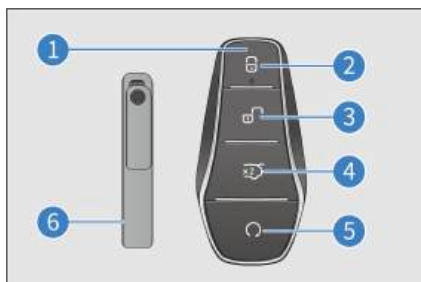

! WARNING

- The button (coin) battery in the smart key is hazardous and both new and used batteries are to be

! WARNING

kept away from children at all times.

- If swallowed or placed inside any part of the body, a lithium button battery can cause severe or fatal injuries in two hours or less.
- Medical attention should be sought immediately if it is suspected the button battery has been swallowed or placed inside any part of the body.

! CAUTION

- The electronic smart key is an electronic component. The following instructions should be observed to prevent damage to the electronic smart key:
 - Do not expose the smart key to high temperatures, such as on the dashboard.
 - Do not disassemble the smart key without authorization.
 - Do not let the smart key hit other objects or fall down.
 - Do not immerse the key in water or clean it in the ultrasonic scrubber.
 - Do not place smart keys with devices that emit electromagnetic waves, such as the mobile phone.
 - Do not attach to the smart key any objects (such as a metal seal) capable of cutting off electromagnetic wave signals.
 - You can register a spare key for the same car. In this case, contact a BYD authorized dealer or service provider immediately.

 **CAUTION**

- If the electronic smart key cannot operate the door within the normal distance, or the key indicator light is dim or off:
 - Check for nearby radio stations or airport radio transmitters that interfere with the normal operation of electronic smart keys.
 - The smart key battery may be exhausted. Check the battery inside the electronic smart key. It is recommended to contact a BYD authorized dealer or service provider for inspection as soon as possible.
- If the smart key is lost, contact a BYD authorized dealer or service provider as soon as possible to prevent theft or accidents.
- Do not change the transmission frequency arbitrarily, increase the transmission power (including additional transmission frequency amplifier), or arbitrarily connect the external detection antenna or switch other transmitting detection antennas.
- Do not generate harmful interference to legal radio communication services when using the smart key. Once any interference is found, stop using the smart key immediately, and take measures to eliminate the interference before continuing to use it.
- The use of micropower radio equipment must be free from interference of all radio services or from radiation of equipments for industrial, scientific and medical applications.

 **CAUTION**

- Do not use it near aircraft or airports.
- People implanted with pacemakers or defibrillators should stay away from the detection antennas of intelligent entry and start systems, as electromagnetic waves can affect the normal use of such devices.
- In addition to people implanted with pacemakers or defibrillators, those who use other electronic medical devices should also consult the manufacturer on the use of such devices under the influence of electromagnetic waves. Electromagnetic waves may bring unknown consequences to the use of such medical devices.
- When leaving the vehicle, always carry your key and lock the vehicle. Never leave anyone (especially children) alone in the vehicle.

Mechanical Key

Use the mechanical key (inside the smart key) to lock or unlock the driver's door. Insert the mechanical key back into the smart key when it is not in use.

Taking out the mechanical key

When using the mechanical key in the electronic smart key, slide the lock-up button in the direction of arrow ① and push the back cover of the smart key in the direction of arrow ②, hook the head hole of the mechanical key with the projection parts at both ends of the back cover of smart key and pull it in the direction of arrow ③ to take out the mechanical key, as shown in the figure.



NFC Key Card*

- With ignition off, tap the NFC key card* against the mark on the driver's side mirror to lock or unlock all doors.

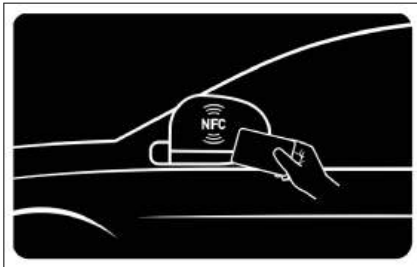

⚠ CAUTION

- NFC key card is an electronic product. The following instructions should be obeyed to prevent function failure of or damage to the card:
 - Do not place the NFC card in the charging area when the wireless charger is on.
 - Do not attach any object (such as a metal seal or metal phone case) that may cut off electromagnetic waves, when using the NFC card.
 - Do not place the NFC card in a position exposed to high temperature, such as on the dashboard.

⚠ CAUTION

- Do not bend the card with force.
- Do not place the card with other hard objects.
- NFC key cards use near-field communication technology, requiring a detection distance of less than 2 cm. Hold your NFC card close to the side mirror for one to two seconds.
- The NFC smart card is a key configured for the vehicle based on the near field communication method. In order to ensure vehicle safety, handle it with care. If it is lost, going to BYD authorized dealer or service provider for blocking of the lost card and re-configuration is recommended.

Locking/Unlocking Doors

Locking/Unlocking with Mechanical Key

1. Push the left side of a hidden door handle, and turn the right side to get a finger height, holding it by a hand.
2. Once the right side is extended, pull the middle of the handle outward to extend the handle.



3. Pull the driver's door handle to its maximum angle. Insert, turn, and then

pull out the mechanical key. Pull on the door handle to open the door.

- To unlock the driver's door: Turn the key clockwise.
- To unlock the driver's door: Turn the key counterclockwise.

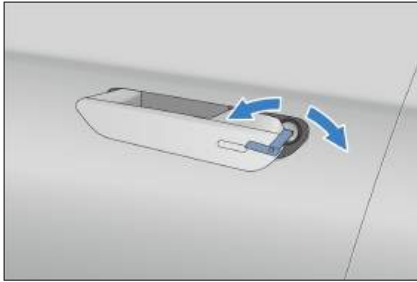

Opening with Interior Door Handle

- When the vehicle is unlocked, pull the handle once to open the door from inside the vehicle.
- When the vehicle is locked, pull the handle twice to open the door from inside the vehicle.



! WARNING

- Do not allow children to play with the door handle, so as to avoid the door opening while driving.
- If there are children in the vehicle, make sure to enable the child protection lock function.

! CAUTION

- As this vehicle is equipped with a child protection lock, the rear doors can only be opened with the interior door handle when the child protection lock is disabled.

Locking/Unlocking with Smart Key

- The wireless remote control is used to unlock or lock all doors at a close distance, and complete additional functions.
- When you enter the active area while carrying a registered smart key, press the button on the smart key slowly and firmly to lock or unlock all doors.

Locking:

- When all the doors and the hood are closed, press the lock button to lock all the doors. The hidden door handles fold automatically. The side mirrors will fold (when the Auto-Fold is enabled) with turn signals flashing once. If the ignition has not been switched off, the side mirrors will not fold, the turn signals will not flash, and the alarm will sound once. Check whether all doors are securely locked.



- If any door is not closed, the side mirrors do not fold, the turn signals do not flash, the door handles do not fold and the alarm sounds once.

- If the hood or trunk is not closed, the side mirrors do not fold, the turn signals do not flash, and the alarm sounds once.

Unlocking:

- Press the unlock button. All doors are unlocked, the hidden door handles automatically extend, and the turn signal flashes twice.
- Unlocking all doors with the smart key turns on interior lights (**DOOR** option on the infotainment touchscreen selected) and keeps them on for 15 seconds, even if no door is opened.
- If the anti-theft alarm system is armed, open any door within 30 seconds after unlocking with the smart key, or all doors will relock automatically and the four door handles retract.

Finding the Vehicle with Smart Key

- When the vehicle is in anti-theft mode, press the lock button. The vehicle sounds a long beep and turn signals flash 15 times. Use this function to locate the vehicle when it cannot be found.
- When the vehicle is in car search mode, press the lock button again. The vehicle enters the next car search mode.

Raising/Lowering Windows with Smart Key

- When the ignition is switched off:
 - Press and hold the lock button on the smart key to raise the four windows.
 - Press and hold the unlock button on the smart key to lower the four windows.

WARNING

- When using the remote control function to raise windows, pay attention to the safety of occupants in the vehicle, and use this function only after making sure the windows are clear from pinching anyone.

REMINDER

- To enable or disable key unlock/lock/closing window functions, go to  → **Vehicle Settings** → **Locks**. (Configurations of the actual vehicle prevail.)

Locking/Unlocking with Microswitch

Locking

- With the doors closed but not locked, press the microswitch on the front door handle while carrying the smart key, then all doors lock at the same time. and the hidden door handles retract automatically and the turn signal flashes once. If the ignition has not been switched off, the side mirrors will not fold, the turn signals will not flash, and the alarm will sound once.

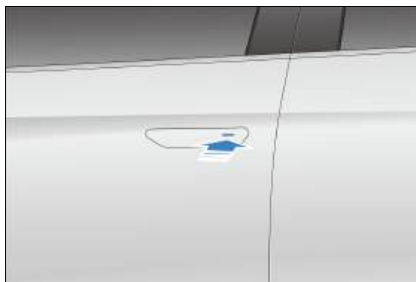

Unlocking

- When the anti-theft alarm system is armed, press the microswitch on the front door handle while carrying the

smart key. All doors unlock and turn signals flash twice. The hidden door handle extends automatically and the turn signal flashes twice.

- If the anti-theft alarm system is armed, open a door within 30 seconds after the unlocking, or all doors will relock automatically and the four door handles retract.
- Pressing the microswitch does not work if:
 - This is performed while a door is being opened or closed.
 - The smart key is left in the vehicle.



REMINDER

- If the smart key is too close to an exterior door handle or window, it may not be possible to activate the entry function.

Raising/Lowering Windows with Microswitch

- When the ignition is switched off, press and hold the microswitch while carrying the smart key to roll up or down all windows. (To enable or disable this function, go to the infotainment touchscreen →  → **Vehicle Settings** → **Locks.**)

Locking/Unlocking the Trunk

Opening the trunk with smart key

Double-press the trunk release button on the smart key. The turn signals then flash twice.



- Anti-forget key function
 - If the key is placed in the vehicle or in the trunk with the vehicle locked, when you close the trunk, the vehicle automatically unlocks and the turn signals flash twice.

Unlocking the trunk with microswitch

- With the vehicle locked, press the rear microswitch while carrying a valid key to unlock the trunk.
- With the vehicle unlocked, press the rear microswitch to open the trunk.

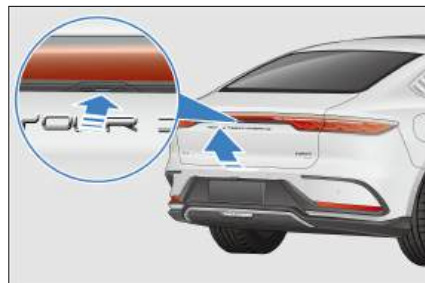

Opening the trunk from inside

- With the vehicle unlocked, pull up the interior trunk lid button to open the trunk.
 - If the vehicle speed is greater than 5 km/h, the trunk lid cannot be opened by pulling up the button.

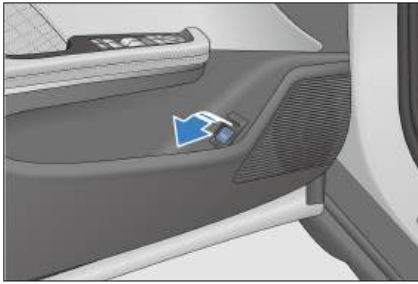

① Trunk close button

- When the trunk lid is open and stationary, press this button to close the lid.
- Press this button a second time to stop the lid at the current position. Press this button again to have the lid move in the opposite direction.

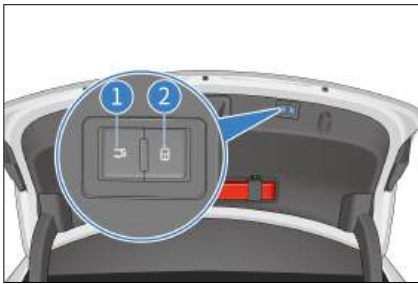

② Vehicle lock button

- When the ignition is off, pressing the lock switch while carrying a valid smart key closes the trunk, locks the entire vehicle, and arms the anti-theft alarm system.

! REMINDER

- Before closing the trunk, make sure doors, windows and sunroof* are properly closed to avoid property loss.

Emergency trunk releasing from inside

1. Flip the rear center console cubby to open its cover.

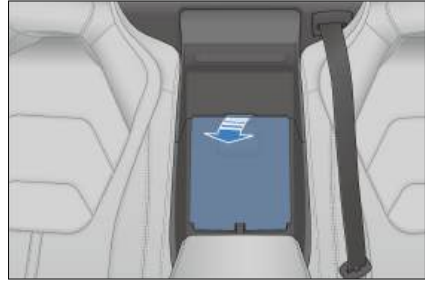

2. Open the trunk lid by pulling its emergency unlocking latch.

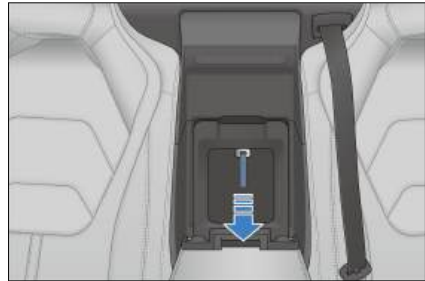

! REMINDER

- When the entire vehicle is powered off, the trunk can be unlocked from inside the vehicle.
- This passage allows you to pick up smaller items in the trunk from inside the vehicle.

Locking/Unlocking with Central Locking

Locking or unlocking the vehicle with the central locking

See **P71** in "Driver's Door Switches" in this chapter.

Locking or unlocking doors automatically

- All doors automatically lock at vehicle speeds above 8 km/h.
- Press the START/STOP button to switch the ignition off. Then, all doors are unlocked automatically.

Locking/unlocking all doors concurrently

- With the anti-theft alarm system disarmed, the backlight of the central lock button turns on if the vehicle is locked and off if the vehicle is unlocked.
- Pressing the central locking button locks all doors so that any attempt to open any door from the outside fails. At this time, pull the interior door handle to unlock a door and pull a second time to open it.

! REMINDER

- All doors unlock automatically when the vehicle suffers a strong impact, which depends on the impact intensity and accident type.

Emergency Vehicle Locking with Mechanical Key

- When the central locking fails, lock the driver's door with the mechanical key. Use the key to turn the emergency locking knobs of the other three doors counterclockwise to the locked state, and then close the doors. At this time, the entire vehicle has been locked so that doors cannot be opened with any of the four exterior door handles.
- To unlock the doors, unlock the driver's door with the mechanical key first, then enter the vehicle, and pull other interior door handles twice to open the doors.



! REMINDER

- Prevent excessive force from distorting or breaking the key during the operation.

Smart Access and Start System

Access

Use the valid smart key to unlock or lock the vehicle doors (see **P49**).

Start-up Function

With the valid smart key inside, press the brake pedal and the START/STOP button to start the vehicle (See **P99**).

Antenna positions

- ① Interior antenna
- ② Exterior antenna

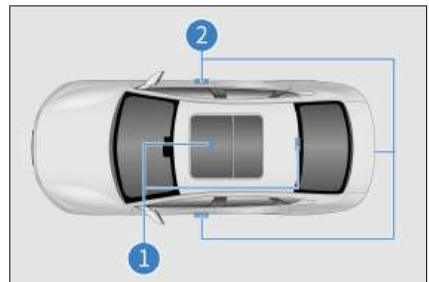

Active area

The smart access and start functions take effect only when the registered smart key is within the active area.

① Active area of the access function: about one meter from the front door handle and the exterior trunk switch.

② Active area of the start function: inside the cabin.

If another smart key is near this vehicle's smart key, unlocking may take longer than usual, which is normal.

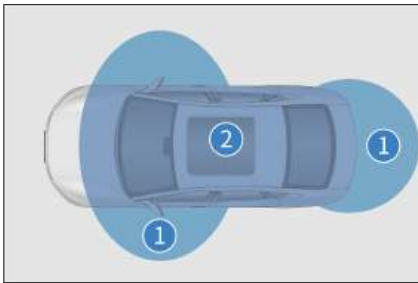

! REMINDER

In the following situation, smart access and start system may not work normally:

- There is a strong electromagnetic field nearby, such as TV towers, power stations, and broadcasting stations.
- The smart key is being carried along with a communication device, such as a two-way radio or mobile phone.
- The smart key is in contact with or covered by a metal object.
- The door handle is operated too quickly.
- The smart key is too close to the handle.

! REMINDER

- Another wireless remote control function is being used nearby.
 - When the smart key battery runs out.
 - The smart key is close to high-voltage equipment or equipment that produces noise.
 - The smart key is being carried along with another smart key or radio-wave-emitting device.
 - Even within the active area, the smart key may not work properly in certain locations, for example, on the dashboard, in the glove box, or on the floor.
-
- If the smart access system is not working properly and it is impossible to enter the vehicle, the mechanical key can be used to lock/unlock the driver's door, or the wireless remote control function can be used to lock/unlock all doors.
 - Pressing the Start/Stop button may not enable the start function due to:
 - Smart key failure. If the smart key warning light comes on and a message ("Low key battery, please replace the battery soon") is displayed on the instrument cluster, the battery of the key may be exhausted.
 - If the smart access and start system cannot work properly due to system failures, bring all smart keys to a BYD authorized dealer or service provider for repair.

Saving battery power

- The smart key communicates with the vehicle even when the vehicle is not running. Therefore, do not leave the

smart key in the vehicle or within two meters from the vehicle.

- Receiving strong electromagnetic waves for a long time drains the battery of the smart key quickly. The smart key must be kept at least one meter away from electrical equipment that generates a magnetic field, such as the following devices:
 - TVs
 - PCs
 - Wireless telephone chargers
 - Electroliers
 - Fluorescent desk lamps

Child Protection Lock

Child protection locks are designed to prevent children in rear seats from accidentally opening rear doors. Such locks are provided on the driver's door switches.

① Child protection lock for the rear left door

② Child protection lock for the rear right door



- To activate child protection locks, press the child protection lock button ① or ②. The corresponding indicator lights up. At this time, the occupants cannot open the rear door on the corresponding side. To unlock the

door, press the child protection lock button for the corresponding side again or use the exterior door handle.

! WARNING

- Before driving, especially when a child is in the vehicle, ensure that the doors are closed and the child protection lock function is enabled.
- Proper use of seat belts and the child protection lock helps prevent the driver and passengers from being thrown out of the vehicle in the event of an accident, and prevent the doors from being opened accidentally.
- After the child protection lock is locked, doors cannot be opened from inside the car, and the window switch for the corresponding rear door cannot be used to raise or lower the window.

Seats

Seat Precautions

- Adjust the driver's seat so that the pedals, steering wheel, and dashboard controls are within the driver's easy control.
- The most effective safeguard while driving is to keep the seatback upright, always resting well on the seatback, and adjusting the seat belt to the right position.
- Secure your luggage appropriately to prevent it from skidding or moving. Luggage in the vehicle should not be higher than seatbacks.

WARNING

- Sitting on a folded seatback, in the trunk, or on cargo is prohibited. Improper seating position or improperly fastened seat belts can result in personal injuries in case of emergency braking or a collision.
- Do not place any items under the seats. The driver may lose control of the vehicle because items placed there affect the seat locking mechanism or accidentally push up the seat position adjustment lever, causing the seat to move suddenly.
- When adjusting the seat, do not place your hand under the seat or near its operating parts, to prevent being crushed.
- After adjusting the seatback, lean back to confirm the seatback has been locked. Seatbacks that are not fully locked can cause personal injuries in an accident or emergency braking.
- Do not put the seatback down while driving or riding in the vehicle. This makes the shoulder strap of the seat belt not properly attached to the body. As a result, occupants could hit the strap in an accident, causing serious injuries to the neck or other parts; or they may slip out of the waist belt, resulting in other serious injuries.
- Do not adjust the driver's seat while the vehicle is in motion, as unpredictable seat movement can cause the loss of vehicle control at this time.
- Do not drive the vehicle until occupants are seated properly.

REMINDER

- Adjust the seat position before fastening seat belts.
- While adjusting a seat, do not let it hit against any passenger or the luggage.

Front Seats

Adjusting Front Seat with Power*

Power front seat adjustment includes seat position adjustment, cushion height adjustment*, seat base angle adjustment*, and seatback angle adjustment. Choose the following methods according to the actual configuration of your vehicle.

① Seat position adjustment switch

- Toggle the seat position adjustment switch back or forth to move the seat backward or forward.
- Move the front end of the switch up or down to change the seat base angle.
- Move the rear end of the switch up or down to raise or lower the seat.



② Seatback angle adjustment switch

Toggle the upper end of the seatback angle adjustment switch to adjust the seatback angle.

! REMINDER

- Releasing the switch stops the seat in this position. Do not place anything under the seat as this may prevent the seat from operating.

Adjusting the Lumbar Support

Lumbar support adjustment switch

- Press the front, rear, upper, or lower part of the switch to adjust the lumbar support.



Second-Row Switch of Front Passenger Seat Adjustment

① Seat position adjustment switch

- Toggle the seat position adjustment switch back or forth to move the seat backward or forward.

② Seatback angle adjustment switch

- Toggle the seatback angle adjustment switch front and back to adjust the seat back angle.

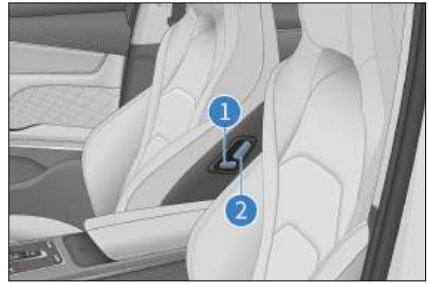

Memory System*

Memory switch position

- The memory system switch is located on the trim of the driver's door. Two driving positions can be recorded into memory.

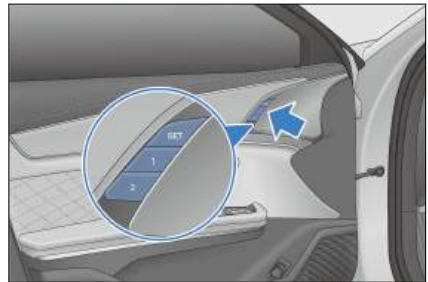

Memory setting function

- Memory setting conditions
 - The ignition has been switched on and the vehicle speed is zero.
 - Seats and side mirrors have been adjusted to the desired positions.
 - No operation is made on the driver's seat and side mirrors.
- Memory setting method
 - Press and release the "SET" button on the seat memory switch, and press either "1" or "2" within three seconds. Then the positions of the seat and side mirrors will be

recorded, and the memory setting finishes.

- Press and hold the "SET" button on the seat memory switch, and at the same time press either "1" or "2" to complete the memory setting.

REMINDER

- If the position button on the memory switch has already been set, the position set will be overwritten.
- Seat memory at position "2" can only be set after seat memory at position "1" has been set for at least three seconds.

Memory wake-up function

- With the gearshift lever in the "P" position, pressing the memory system switch enables the driver's seat memory system to perform memory wake-up, if:
 - The anti-theft alarm system has disarmed.
 - The vehicle speed is zero.
 - Memory switch signals are valid.
- You can interrupt the current memory wake-up operation by the following ways:
 - Press or toggle any of the driver's seat adjustment switches.
 - Press any memory system button: "SET", "1", or "2".

WARNING

- Ensure there are no obstacles around the seat before activating the seat memory wake-up function.

WARNING

- Ensure that no part of your body is within the seat's movement range during the seat memory wake-up process.
- Do not allow children to operate the memory switches to prevent any injury during seat movement.
- The automatic driver seat function can be interrupted by closing the left/right front door while the seat is moving backward or by opening the left/right front door while the seat is moving forward.

Greeting function

- Normal functions
 - Automatic back: After the ignition is switched off, the seat automatically goes backward when the driver's door is open or when opening the driver's door.
 - Automatic forward: If the opened driver's door is closed after the vehicle is switched on to another gear from "OFF" or when the vehicle is switched off, the seat automatically moves forward to the position from which it previously moved back.
- User settings
 - You can cancel or restore automatic forward and back functions via the options on the Vehicle Settings screen on the infotainment touchscreen.

Heating and Ventilation Systems for Front and Rear Seats*

- When the ignition is switched on, turn on or off the heating & ventilation function by tapping buttons on the infotainment touchscreen.

- Swipe the left/right button to select the rear seat to be heated or ventilated.

Heating adjustment

- Seat heating: On the infotainment touchscreen, tap the seat heating controls to select a heating level: Mode 1 and Mode 2.
- Tap **OFF** to disable seat heating.



Ventilation adjustment

- On the infotainment touchscreen, tap the seat ventilation controls to select a ventilation mode: Mode 1 and Mode 2.
- Tap **OFF** to disable seat ventilation.

Heating of the rear windshield and side mirrors

- Enable or disable the heating of the rear windshield and side mirrors by using the heating switch for the rear windshield and side mirrors.

Rear Seats

- The rear seat adjustment handle is located on the trim of rear door.
- Pull back the handle ① to move the seatback backward.
- Push forward the handle ① to move the seatback forward.



Steering Wheel

Steering Wheel Switches

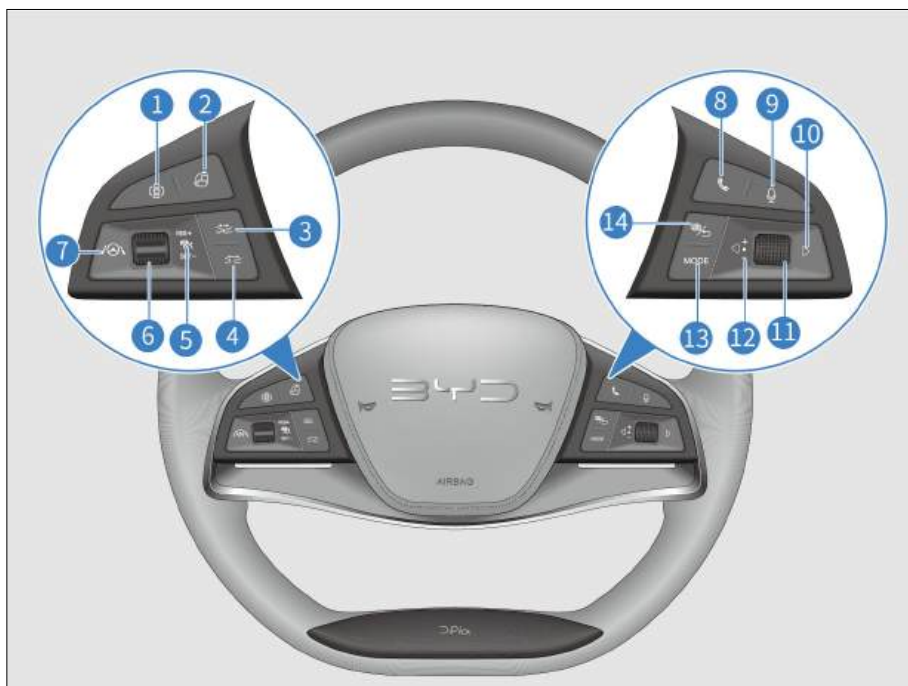

- 1 Panoramic view
- 2 Custom
- 3 Distance -
- 4 Distance +
- 5 +/Reset or -/Set
- 6 Lever
- 7 ICC

- 8 Call
- 9 Speech recognition
- 10 Right
- 11 Scroll button
- 12 Left
- 13 Mode
- 14 Instrument cluster/Back

The audio control switch is accessible when the ignition is switched on.

Left-hand buttons

+ /Reset

- Activates the adaptive cruise control (ACC) system and uses the previous system settings.

Cruise switch

- Turns the cruise system on or off.

-/Set

- Sets the current speed to the target cruise speed.

Distance -

- Reduces the distance from the vehicle ahead by one notch when the ACC function is enabled. A total of four notches are available.

Distance +

- Increases the distance by one notch when the ACC function is enabled. A total of four notches are available.

ICC

- Turns ICC on or off.

Custom

- Press the button to respond to the custom function, or press and hold it to go to the interface to customize the corresponding functions.

Panoramic view

- Turns panoramic view off if already in panoramic view mode, or on if not in panoramic view mode.



REMINDER

- For instructions on using cruise control, see **P107**.

Right-hand buttons

Scroll button

- Adjusting infotainment system volume when the instrument cluster is not in menu mode:
 - Roll the button upward to increase the volume. The button is non-operational when the volume reaches the highest.

- Roll the button downward to decrease the volume. The button is non-operational when the volume reaches the lowest.

- Press down the button to mute.

- When the instrument cluster is in menu mode:
 - Roll the button upward to select the upper level-2 or level-3 menu items.
 - Roll the button downward to select the lower level-2 or level-3 menu items.

- Press down the button to go to the next-level menu or confirm the current setting.







CAUTION

- The infotainment system is muted once the instrument cluster is set to the menu mode. To adjust infotainment system volume, exit the instrument cluster menu mode first.

Left/Right button

- When the infotainment system is in radio mode:
 - Press the ◀ button to select previous radio station.
 - Press the ▶ button to select next radio station.

- When the infotainment system is in USB/Bluetooth music/third-party music app/other modes:
 - Press the ◀ button to play the previous track (track number -1).
 - Press the ▶ button to select a record upward on the Bluetooth call record or phonebook screen.

- Press the  button to play the next track (track number +1).
- Press the  button to select a record downward on the Bluetooth call record or phonebook screen.
- When the instrument cluster is in menu mode:
 - Press the  button to switch to level-1 menu and its submenus on the left.
 - Press the  button to switch to level-1 menu and its submenus on the right.

Call

- Press this button to make or receive a call (the audio system is muted at the same time).
- When a Bluetooth-unrelated screen is currently displayed, press this button to switch to the phone selection screen if Bluetooth is disconnected, or to the Dial screen if Bluetooth is connected.
- After entering a phone number on the Dial screen or selecting a record on the Call Log or Contacts screen, press this button to dial the number.
- When Bluetooth is connected, but no phone number is entered on the Dial screen, press this button to switch to the Call Log screen. Press this button again to call the first dialed number on the call history.

Speech recognition

- Press this button for the infotainment touchscreen to switch to the voice recognition screen.
- Press this button again to re-enter a voice command.

Instrument cluster/Back

- When the instrument cluster is not in the menu mode, press this button to view the instrument cluster menu.
- When the instrument cluster is in menu mode, press this button to return to the upper-level screen, or to exit the menu if there is no upper-level screen.
- When on the Bluetooth call screen, press this button to end the call.

Mode

- Selecting a mode: Press the Mode button to switch between media apps, peripherals, and pre-installed third-party audio/video apps.

Horn

- Press the horn button area to honk the horn, and release to stop honking.



CAUTION

- Avoid pressing honking for too long, as the horn may be damaged.



REMINDER

- Observe the traffic laws and use the horn properly.

Adjusting the Steering Wheel

Adjusting the Steering Wheel with Power*

The steering wheel is adjustable only when the ignition is switched on.

- Toggle the electronic switch up/down/forward/backward to adjust the angle or axial position of the steering wheel.

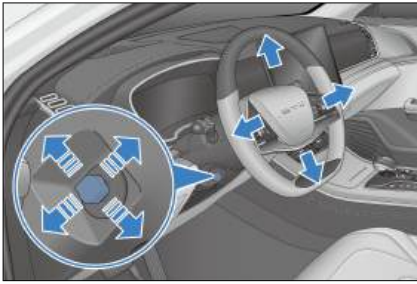

! WARNING

- Never adjust the steering wheel while driving, as this is under risk of impaired vehicle control, which can lead to accidents.
- After adjusting the steering wheel, move it up and down to verify that it is securely locked.

Adjusting the Steering Wheel Manually*

- To adjust the steering wheel position, hold it and operate as follows:
 - Push down the steering wheel adjustment handle, adjust the steering wheel to the desired position, and then return the handle to its original position.

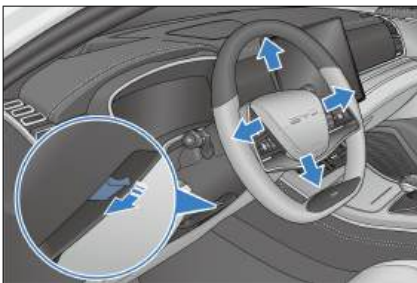

! WARNING

- Never adjust the steering wheel while driving, as this is under risk

! WARNING

of impaired vehicle control, which can lead to accidents.

- After adjusting the steering wheel, move it up and down to verify that it is securely locked.

Steering Wheel Greeting*

- With the vehicle having no speed (≤ 3 km/h), if the ignition is switched off and the driver's door is opened, the column of the steering wheel is tilted up to retract from the current position for the driver to get off the vehicle, and tilted down to extend to the previous position when the door is closed.
- If the ignition is switched on and the driver's door is opened, the column is tilted up to retract from the current position for the driver to get on the vehicle, and tilted down to extend to the previous position after the driver sits in the seat and closes the door.

Heated Steering Wheel*

Turn on the heated steering wheel* in any of the following three ways:

1. Go to the infotainment touchscreen \rightarrow \rightarrow **Vehicle Settings** \rightarrow **A/C** to access the A/C operation interface. Tap the ventilation and heating settings, then the button below the heated steering wheel icon: ON indicates that the feature has been turned on, and OFF indicates that the feature has been turned off.
2. Go to the drop-down shortcut menu, and tap the heated steering wheel icon. The button is highlighted when the feature is on and is gray when off.

- Voice control: Activate voice control to turn the heated steering wheel on or off.

⚠ CAUTION

- The heated steering wheel shut off automatically after working for 30 minutes.

Power-Assisted Steering Mode Settings

- The feel of steering assistance varies from person to person, and so do the evaluation and needs for this feel.
- To set the steering mode, go to the infotainment touchscreen → 🚗 → **Vehicle Settings** → **Smart Chassis** → **Steering mode**, and select **Comfort** or **Sport**.

! REMINDER

- Setting the power steering to sport mode is suggested if the steering wheel feels light when the vehicle is running at a high speed.

Switches

Light Switches

Set the light switch to 0 to turn off all lights except for daytime running lights. When the daytime light feature is enabled on the infotainment touchscreen, the daytime running lights are on; and when this feature is disabled, the daytime running lights turn off.

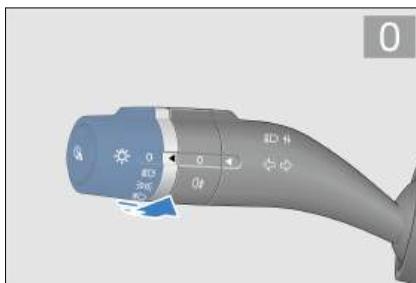

Auto lights

Set the light switch to 🚗. The body control module captures the brightness data from the light intensity sensor to automatically turn the position lights and low beam on or off.

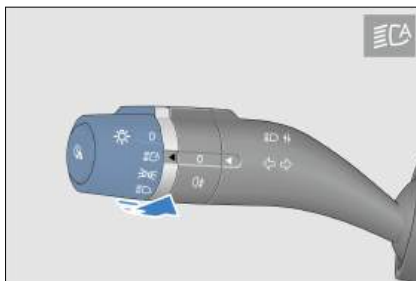

! REMINDER

- The light intensity sensor is located on the top of the windshield. Do not block the sensor or let anything splash on it.

Position lights

Set the light switch to 🚗 to turn on position lights.

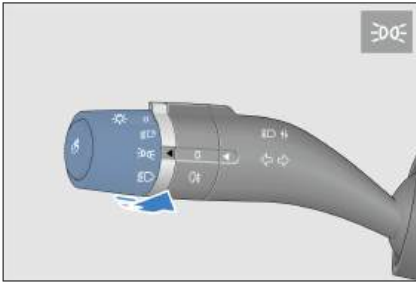

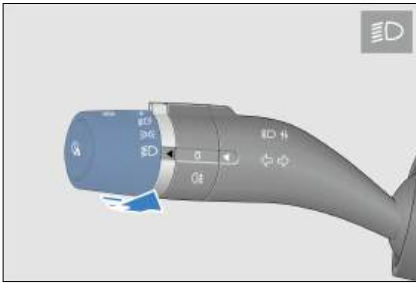

Low beam

Set the light switch to  to turn on the low beam.



Rear fog lights

Set the light switch to  and rotate the fog light dial to  to turn on rear fog lights. The light switch automatically returns to .

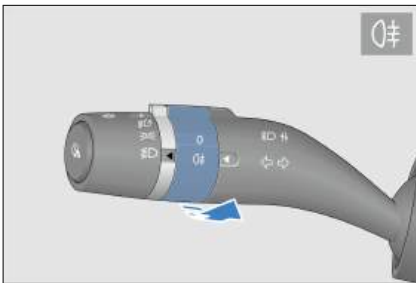

High beam

Set the light switch to  and push the light switch lever down (away from the steering wheel) to turn on the high beam.

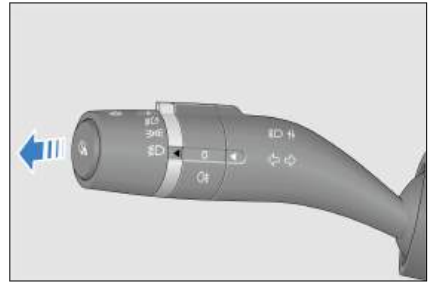

Overtaking light

Pull up the lever (toward the steering wheel) to turn on the overtaking light. Release the lever for the light switch to automatically reset. The overtaking light turns off.

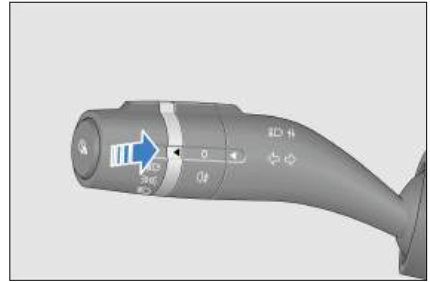

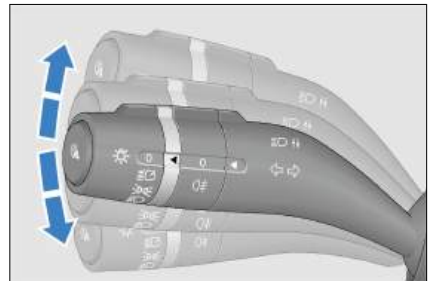

Turn signals

- Push up the lever to signal right turn. The right turn signal and its indicator on the instrument cluster flash.
- Pull down the lever to signal left turn. The left turn signal and its indicator on the instrument cluster flash.









Auto light off

- Conditions to activate the auto light off function: To activate this function, set the light switch to  or  and switch off the vehicle power.
- When the auto light off function is activated, the headlights, position lights, rear fog lights, and high beams turn off after 10 seconds if the driver's door is closed.
- When the auto light off function is activated, the headlights, position lights, rear fog lights, and high beams turn off after 10 minutes if the driver's door is open.
- After the lights turn off automatically, if the light status changes, these lights come on in the new status. If the conditions to activate the auto light off function are still met, the function is activated again.
- Disabling of the auto light off function: When the vehicle is powered on, the auto light off function is disabled, and the light switch can be operated normally.
- If the auto light off function has turned off the lights and the anti-theft alarm system has been armed, disarming the alarm system makes the lights come on again automatically. If the driver's door remains closed, the lights go off again after 10 seconds. But if any door is open, it turns off the light in 10 minutes.

Lighting delay

- When the vehicle is powered on, tap  → **Vehicle Settings** → **Lights** to set the delay time.



- Follow me home headlight:
 - The lighting delay is 10 seconds by default and can be set on the infotainment touchscreen. With the light switch set to , , or , when you power off the vehicle, lock four doors, and are leaving the vehicle, the corresponding lights keep on for 10 seconds (or the set time period).
- Headlights before entering:
 - The lighting delay is 10 seconds by default and can be set on the infotainment touchscreen. With the light switch set to , , or , when you unlock and are approaching the vehicle, the corresponding lights keep on for 10 seconds (or the set time period).

Adjusting Headlight Height

- When the low beam is on, tap  → **Vehicle Settings** → **Lights** → **Adjust headlight height** on the infotainment touchscreen to adjust the vertical beam angle of the headlights.



Loading Conditions	Recommended Lighting Level
One person in the driver seat	0~2
The driver, plus one passenger in the front seat	0~2
All the seats occupied	0~2
All seats occupied, plus an evenly distributed load in the trunk	1~3
Driver, plus an evenly distributed load in the trunk	1~3

- Vehicle loading conditions may differ. Adjust accordingly.

High Beam Assist (HMA)

- The HMA system uses a multi-purpose camera on the front windshield to determine current driving conditions and, if necessary, automatically switches between high and low beams.
- Tap  → ADAS → Driving Assist to turn on HMA.





Activating HMA

- Set the light switch to . When the vehicle speed is above 35 km/h and the light meets conditions, HMA is automatically activated and switches between low beam and high beam based on the current driving environment.

REMINDER

- When HMA is activated, the HAM indicator light up on the instrument cluster.

Deactivating HMA

- How to deactivate HMA:
 - Set the light switch to any position except .
 - Tap  → **ADAS** → **Driving Assist** or use the drop-down shortcut menu to turn off HMA.
 - Manually activate high beam.

System suppression conditions

- The intelligent high & low beam system is suppressed in any of the following situations:
 - The vehicle speed is below 35 km/h.
 - Fog lights or turn signals are turned on, or the vehicle makes a sharp turn.

System Limitations

- HMA may be unexpectedly activated or fail to activate in the following cases (in such cases, drivers are advised to control the lights manually):
 - There are traffic participants with poor lighting (such as pedestrians

and bicycles), railways or waterways nearby, or wild animals on the roads.





- The front windshield is dirty, covered in mist, or blocked by stickers or decorations.
- There are strongly reflective objects around, such as traffic signs on motorways and water reflection on the road surface.

CAUTION



- In case there is a collision or sensors have been reinstalled, contact a BYD authorized dealer or service provider to calibrate the sensors, so as to avoid affecting system performance.

Wiper Switches

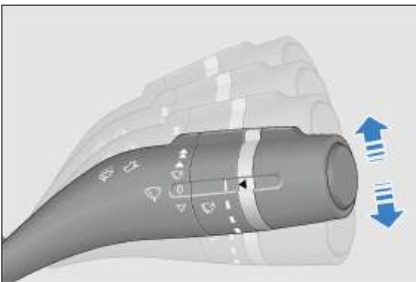

Front Windshield Wipers and Washer

- The lever is used to control the windshield wipers and washer. It has five modes:
 -  : Fast
 -  : Slow
 -  : Auto wipers/Intermittent
 -  : Off
 -  : Point-wiping



- Push up or pull down the lever to select a mode.
- In slow and fast modes, the wiper operates continuously.
- Pulling down the lever from the  position activates the point-wiping mode . The wipers wipe at a low speed until you release the lever.

Auto Wipers/Intermittent

- The rain sensor automatically controls the operation mode of wipers based on the rainfall, and it is located in front of the interior rearview mirror on the front windshield inside the vehicle.
- To use the auto wiper function, turn the wiper switch to the automatic mode, go to the infotainment touchscreen →  → **Vehicle Settings** → **Greeting** and enable **Auto wiper**.
- To use the intermittent wiper function, turn the wiper switch to the automatic mode, and disable auto wiper in infotainment touchscreen →  → **Vehicle Settings** → **Greeting**.
- The automatic wiper function has four sensitivity levels. The higher the lever, the higher the sensitivity. When using the automatic wiper function, change the sensitivity by adjusting the toggle based on real-time rain conditions. If the wiper reacts to rain too quickly, reduce the sensitivity; if the wiper reacts to rain too slowly, increase the sensitivity.

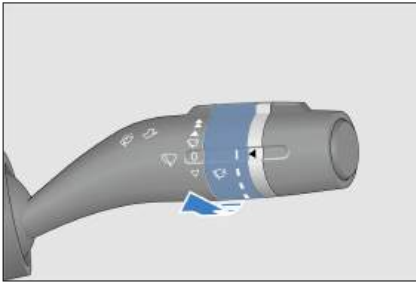

WARNING

- With the ignition on and the wiper switch at , touching the glass on the top of the sensor by hand or wiping it with a cloth may cause the wiper to work and thus lead to an accident.
- Turn off the automatic mode of wiper during the vehicle washing process, in dry seasons or in rainless weather to prevent inadvertent wiper operation.
- The rain sensor cannot adequately recognize each rainfall and then activate wipers. When rainwater on the front windshield affects visibility, timely change infotainment settings when necessary to disable the automatic function and use the wipers manually instead.



CAUTION

- When the wiper stops midway for snow accumulation and other reasons, please turn it off, park the vehicle in a safe place, and remove the snow and other debris, so that the wiper can work properly.
- The sensor may occasionally fail to properly identify snowflakes on it as they have various

CAUTION

shapes, which could lead to wiper malfunction. After the snow has melted, it may result in automatic wiping of the wiper.

REMINDER

- With the wiper handle at , the wiper will perform a wiping action whenever the wiping sensitivity is increased by one shift; when the wiper is turned from OFF to , the wiper will perform a wiping action.

Front windshield washer 

Pull up (toward the steering wheel) the wiper switch for the system to only spray water without wiping if pull-up time is short (within 0.5 seconds), or spray water and wipe it at a low speed if pull-up time is long. Release the wiper switch for the wiper to automatically wipe three times and then return to its original position.

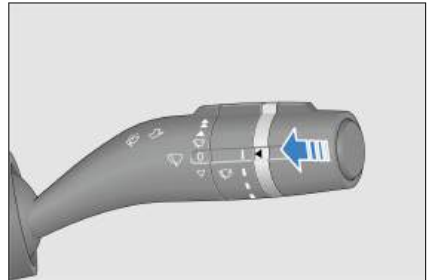

Driver's Door Switches

Power Window Switches

- The window control switch at the driver's side contains four buttons to roll up or down windows on four doors, respectively.

- Press a switch to roll the window down.
- Pull a switch to roll the window up.
- While using the switch, release it to stop window halfway.



Automatic operation (when equipped with anti-pinch function)

- Rolling down: Press a switch to the second notch and release. The corresponding window rolls down automatically.
- Rolling up: Pull a switch to the second notch and release. The corresponding window rolls up automatically.
- To stop the window halfway, gently push the switch in the opposite direction.

Manual operation

- Rolling down: Press the switch to the first notch and do not release. The corresponding window is rolled down manually.
- Rolling up: Pull the switch to the first notch and do not release. The corresponding window is rolled up manually.

Window Anti-pinch

Anti-pinch function

If someone or an object is caught by the window when it is rolling up, the window stops and rolls down automatically.

Initialization of anti-pinch function

- If the low-voltage battery is disconnected while a window is being rolled up or down, the automatic rolling-up and anti-pinch functions both cease to work.
- Pull and hold the window control switch for the first time, so that the window rises to the top for stalling for at least 400 ms. Release your hand when the window rises to the top.

WARNING

Please follow the precautions below to prevent serious injury or death from window closing:

- Before operating the power windows, ensure that all passengers do not have any body parts that can be caught in the window.
- Do not allow a child to operate the power windows.

CAUTION

- Excessively frequent activation of the anti-pinch function can activate the regulator motor's overheat protection.
- Never try to deliberately activate the anti-pinch function with any part of your body.
- The anti-pinch function may not work if an object is jammed into the window when it is almost completely closed.
- Contacting a BYD authorized dealer or service provider for maintenance is recommended if



CAUTION

the windows' automatic closing function or anti-pinch function is not working normally.

Central Locking

The driver's door is equipped with power door lock switches. Both switches can lock or unlock all doors.

① Unlocking

Press the central unlock button. All doors are unlocked and the red lock indicator turns off.

② Locking

Press the central lock button. All doors are locked and the red lock indicator lights up.



Side Mirror Adjustment Buttons

Side mirror selection buttons



Left side mirror button



Right side mirror button

Side mirror adjustment buttons

Press this button to adjust the side mirror lens to a right position.

Side mirror folding control

Press this button to fold or expand side mirrors.



Odometer Switch

- The odometer information displayed includes:
 - Total mileage: total mileage the vehicle has traveled.
 - Mileage 1/Mileage 2: different mileages driven since the two trip odometers have been set to zero.
- The odometer is in the unit of km by default. You can set the unit to mile in the unit settings on the infotainment touchscreen
- Press the odometer switch to switch between "Total Mileage" - "Mileage 1" - "Mileage 2" - "Total Mileage". The switching status is displayed accordingly on the instrument cluster.
- Press and hold "Mileage 1" and "Mileage 2" to clear the mileage information.

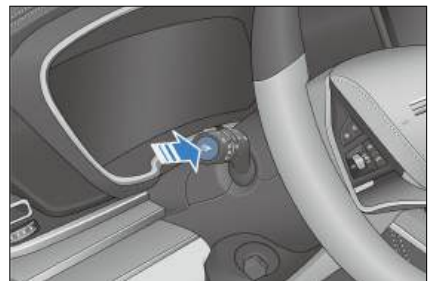

- The mileage per trip (Mileage 1 or Mileage 2) can be calculated using a trip odometer.

Mode Switches

These switches enable drivers to select from the different regenerative braking, snow, and ECO, SPORT or NORMAL modes.

① Regenerative braking mode button

- Regenerative braking mode includes 2 modes.
- The default setting is the standard regenerative braking mode.
- Toggle up the lever ① to increase regenerative braking force.

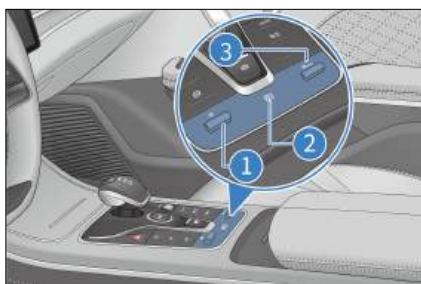

② Snow mode button

- Press down the snow mode switch ② to put the vehicle in snow mode.
 - This mode is recommended on fairly strong surfaces covered in slippery materials such as grass, snow, ice, or gravel.
 - Although snow mode optimizes traction, driving performance, and maneuverability, it is recommended to avoid sudden acceleration or high speed.

③ MODE switch

- Ecology, Conservation, Optimization(ECO): moderate vehicle

power, comfortable driving and riding experience, and better economy.

- Normal mode (NORMAL): standard settings mode, the default driving condition.
- Sport(SPORT): The vehicle shows good power performance, but its acceleration performance is reduced at low SOC, or too high or low temperatures.
- The default setting is Normal(NORMAL).
- Move up the lever ③ to switch the vehicle to the ECO mode.
- Move down the lever ③ to switch the vehicle to the SPORT mode.
- Move down the lever ③ repeatedly to cycle through NORMAL → SPORT → ECO → NORMAL mode.
- Move up the lever ③ repeatedly to cycle through NORMAL → ECO → SPORT → NORMAL mode.



CAUTION



- Because ESC activation limits the engine torque, momentarily deactivating ESC may help if the vehicle is stuck in deep snow. Be sure to turn ESC back on once you overcome the situation.



REMINDER

- The driving modes are ranked as SPORT, NORMAL, and ECO, in descending order of driving power. Be sure to drive safely.

Hazard Warning Light Switch

When the  button is pressed, all turn signals and turn signal indicators on the instrument cluster start flashing. They all stop flashing when the  button is pressed again.

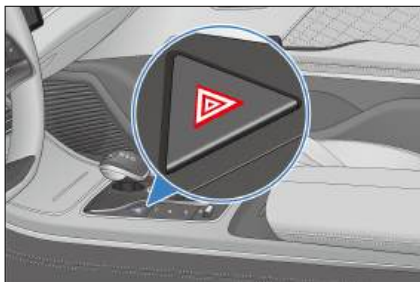

CAUTION



- The hazard warning lights are used to alert drivers and pedestrians of possible risks.



Sunroof Switch

Panoramic Sunroof

The sunroof can only be operated when the vehicle is powered on or when the power-off delay has not expired.



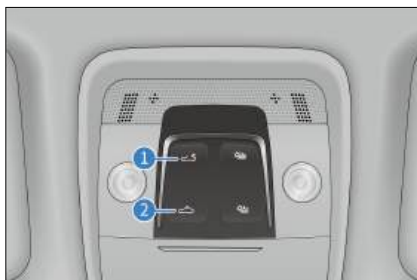

Opening the sunroof

- Press and hold the sunroof open button  to open the sunroof manually. Release the button midway to stop the sunroof at its current position.
- Pressing the sunroof open button  and release it immediately, the sunroof tilts up for ventilation. Pressing the button again will set the sunroof to open automatically by about 2/3. Touching the button once more will

open the sunroof completely. If button  or  is pressed when the sunroof is opening, the sunroof will stop at its current position.







Closing the sunroof

- Press and hold the sunroof close button  to close the sunroof. The sunroof will stop if the button is released.
- If the sunroof has been initialized, releasing the sunroof close button  immediately after touching it closes the sunroof automatically. For the sunroof to stop at its current position, press the  or  button midway.

Opening/Closing Sunshade

Opening the sunshade

- Press and hold the sunshade open button  to open the sunshade. Release the button midway to stop the sunshade.
- Release the sunshade open button  immediately after touching it. The sunshade opens automatically. For the sunshade to stop at its current position, touch the  or  button midway.



Closing the sunshade

- Press and hold the sunshade close button ② to close the sunshade. Release the button midway to stop the sunshade at its current position.
- If the sunshade has been initialized, releasing the sunshade close button ② immediately after touching it closes the sunshade automatically. For the sunshade to stop at its current position, touch the ① or button ② midway.

CAUTION

- When opening or closing the sunroof sunshade, avoid forceful contact with its curtain to prevent damage.

Sunshade linkage function

- When the sunroof is opened, the sunshade will be opened together with the sunroof.

Sunroof Anti-pinch

If the sunroof or sunshade closing process is obstructed by anything, it will stop and slightly retract.

WARNING

- Keep clear of the sunroof when it is opening or closing, or severe injury may occur.

WARNING

- Passengers must refrain from sticking hands or their heads out through the sunroof. Otherwise, severe injury or even death may occur.

CAUTION

- Trying to open the sunroof in outside temperatures below 0°C or when it is covered in snow or frost may damage the sunroof or its motor.

Initialization

- With the ignition on, the signal remains valid and the sunroof is in the uninitialized state, try the following steps for initialization:
 1. Pressing the sunroof close button to stop the sunroof to the stalling point.
 2. Close the sunshade and stop it to the stalling point.
 3. Open the sunshade fully.
 4. Open the sunroof fully.
 5. Close the sunshade fully.

CAUTION

- Throughout the initialization process, press and hold the Off button of the sunroof switch until the initialization is complete.
- The sunroof and sunshade are initialized simultaneously.

E-Call Switch

Emergency Call(E-Call)*

- E-Call* refers to emergency call. The E-Call system can be triggered manually within two seconds by pressing and holding the SOS button.
- The E-Call system activates automatically in the event of airbag deployment or the detection of a severe collision.



- When triggered, the system automatically makes an emergency call and communicates standard information to a public safety answering point (PSAP).

CAUTION

- The dialed emergency call cannot be manually canceled from the vehicle until the PSAP hangs up or has not been answered 10 consecutive times.

Interior Light Switch

Front Interior Lights

In any ignition status, touch the cover of front interior lights to turn on the lights.



Side Interior Lights

Touch the cover of interior lights to turn on the lights.

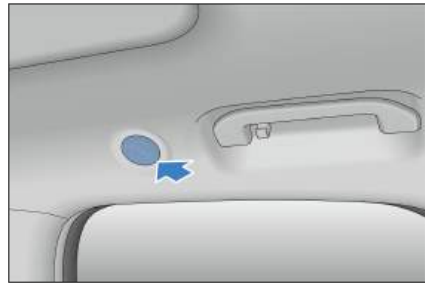

Smart Ambient Lights

When the door is opened, the smart interior ambient lights turn on automatically to create a pleasant environment in the cabin.

- Tap  → **Vehicle Settings** → **Lights** to set the color, brightness, or lighting area.



04

USING AND DRIVING

Charging/Discharging.....	78
Battery.....	91
Usage Precautions.....	95
Starting and Driving.....	99
Driver Assistance.....	107
Other Main Functions.....	136

Charging/ Discharging

Charging Instructions

- Charging equipment uses high-voltage current. Minors are prohibited to charge the vehicle or touch the charging equipment. Keep them away from the vehicle during charging.
- Charging may affect medical or implanted electronic devices. Consult the device manufacturer before charging.
- Charge the vehicle in a relatively safe environment, and avoid charging in damp areas, or areas with fire or heat sources.
 - Protect the charging equipment against water contact on rainy days.
- Before charging:
 - Ensure that power supply equipment, charging connector, charge port, and charging connection device are free of defects, such as cable wear, rusted ports, cracked casings, or foreign objects in the ports.
 - Do not charge the vehicle when the charging connector's or port's plug, socket, or metal terminals are loose or damaged by rust or corrosion.
 - When the charging connector, port, power plug, or socket is visibly stained or damp, wipe them with a dry and clean cloth to ensure the connection is dry and clean.
- Use charging equipment that complies with local standards.
 - To avoid charging failure or fire, do not modify, disassemble, or repair the charging equipment and related ports. Contact a BYD authorized dealer or service provider for handling if there is a fault.
- Do not use charging equipment that does not meet safety standards or has potential safety hazards. Do not allow children to use the charging equipment and keep animals away from the vehicle while charging.
- Ensure that your hands are properly dry before charging.
- If anything abnormal is found in the vehicle or charging equipment during charging, stop immediately and contact a BYD authorized dealer or service provider.
- Always observe the following charging precautions to prevent damage to the vehicle:
 - Do not shake the charging connector, otherwise the vehicle charge port may be damaged.
 - Whenever possible, do not charge the vehicle during a thunderstorm, under risk of lightning strikes.
- Do not open the hood for maintenance while charging.
- After charging, do not disconnect the charging equipment with wet hands or while standing on any wet surface.
 - Before driving, ensure that the charging equipment is disconnected from the charge port.

Compatibility of vehicle and charging infrastructure

- These signs are located on the vehicle charging socket and charging infrastructure components (e.g., charging stations and sockets).

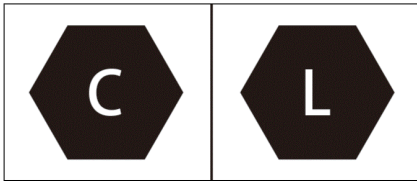

- These signs refer to standardized charging systems in accordance with DIN EN 62196.

Charging Precautions

- When the SOC bar on the instrument cluster turns red, the high-voltage battery is about to be exhausted. Please charge it immediately, otherwise the service life of the high-voltage battery will be reduced.
- Mode 2 charging means charging with an AC charging connector. Use a dedicated AC line and power outlet that meets local standards. The purpose of using a dedicated line is to protect the line from tripping due to line breakage or high-power charging of the high-voltage battery. Using a line other than dedicated lines may affect proper operation of other devices on the line.
- Avoiding damage to the charging equipment (precautions for charging equipment):
 - Prevent the charging equipment from suffering any mechanical impact.
 - Do not place the charging equipment near heaters or other heat sources.
- Before charging:
 - Make sure that the charging connector and charge port are free of foreign objects, and that the protective cap of the charging connector terminal does not get loose or deformed.
 - Hold the charging connector, align the connector with the charge port and push it in, making sure that they are properly connected.
- When charging is complete:
 - Stop charging first and make sure the charge port is unlocked.
 - Hold the charging connector with one hand and remove the connector by pressing and holding its button.
 - Do not force the charging connector out while the charge port is locked, otherwise the charge port may be damaged.
- Precautions:
 - The A/C can be used as normal while the vehicle is being charged. To ensure the charging power, it is recommended not to turn on the A/C.
 - It is recommended that no one stay in the vehicle during charging.
 - It is recommended to park the vehicle in a ventilated area during charging.
 - The vehicle system automatically stops charging when the high-voltage battery is fully charged. The charge port is equipped with an electronic lock. Unlock it before unplugging the charging equipment.
 - To stop DC charging, turn off the charger before disconnecting the charging connector. In Mode 2 charging, remove the charging connector and then the power plug.
 - When charging is complete and the charging connector is unplugged, make sure that the charge port's cap and door are closed, otherwise water or foreign materials may enter the port and affect its normal use.
 - Before starting the vehicle, ensure that the charging equipment is

disconnected. The locking mechanism can damage the charging equipment and the vehicle if the vehicle is started with the charging connector incorrectly inserted.

- Battery temperatures that are too low or too high compromise vehicle charging performance.
- The temperature control system can improve low-temperature charging capacity of the battery. Due to output capacity limitations of charging piles, the charging time is extended, the heating time becomes longer, and the power consumption of heating is increased. These are normal phenomena.
- For faster low-temperature DC charging, charging from low SOC is recommended because, due to the low battery temperature, the charging current is small for vehicles with high SOC in low-temperature environments.
- To improve your experience, it is recommended to charge the vehicle immediately after using it, as the battery is relatively hot and has better charging performance.
- Turning A/C on during low-temperature charging affects the performance of battery temperature control system and charging performance.
- It is normal that when the battery temperature control system is working during charging, the charging power displayed on the instrument cluster may fluctuate temporarily.
- Before charging is complete, battery equalization is activated for longer battery life and thus the charging time may be longer.
- In case of high-temperature high-power DC charging, the performance

of battery temperature control system may be affected by the A/C in the passenger compartment, and the charging performance may degrade, resulting in an extended charging time. To ensure charging efficiency, it is recommended to keep the A/C off during charging.

- When the heating or cooling function is enabled during charging, it is normal that both charging time and power consumption increase slightly.
- During charging, battery cooling may start, and the compressor, fan and other components work when necessary. It is normal that there will be some noise under the hood.
- During charging, the estimated remaining time to full charge is displayed on the instrument cluster. It is normal that the remaining time to full charge may vary slightly depending on the temperatures, SOC, and charging facilities.
- If the charge port door is frozen due to weather or other reasons, do not force it open.



REMINDER

- Do not open the charge port door forcibly when it is locked.
- Do not forcibly insert the connector with the electric lock engaged.
- Do not close the charge port door when the port cap is fully open.
- When the vehicle is charged with an external power supply, it is normal that the cooling fan and A/C compressor may operate automatically for the high-voltage battery to cool down.





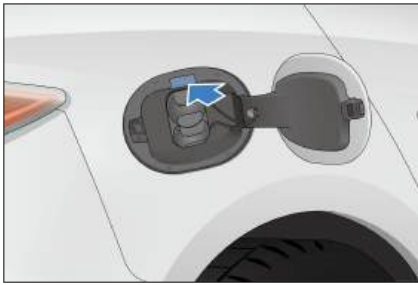

General Charging Troubleshooting

Fault	Possible Cause	Solution
Charger is connected, charge starts, but battery is not charged	The high-voltage battery has been fully charged.	When the high-voltage battery is fully charged, the charging will stop automatically.
	High-voltage battery temperature is too high or too low.	Keep the vehicle in an environment with appropriate temperature and charge it when the temperature becomes normal.
	Low-voltage battery over-discharges.	Replace the low-voltage battery.
	Charging equipment fails.	If it is verified that the charging equipment's power indicator is working properly, or that there are no other unusual indications, change the charging equipment or contact the charging equipment supplier.
	Vehicle display fails.	Verify that there is a charging system fault message on the instrument cluster, then stop the charging. It is recommended to contact a BYD authorized dealer or service provider.
Charging stops midway.	AC grid outage	Charging will automatically restart when the power grid is restored.
	Charging cable is not connected properly.	Verify that the charging connection cable is not loosely connected.
	Charging connection switch is pressed.	If the charging connection switch is pressed, the charging will stop. The charging connection should be connected again to start charging.
	High-voltage battery temperature is too high or too low.	If the instrument cluster shows that EV function is limited, the charging will automatically stop. Charge the vehicle when the battery temperature returns to a normal level.
	Vehicle or charging pile fails.	If there is any fault prompt for the charging pile or the vehicle, it is recommended to contact a BYD authorized dealer or service provider.

Vehicle AC Charge/Discharge Indicator

- The charging/discharging indicator is located in the charge port door on the right side of the vehicle body, and it indicates the charging state in green, yellow, red, blue, and white respectively.
- If the charging/discharging connector is not connected, the indicator remains solid white for a period of time. If the vehicle is locked during use, the indicator is on for a period of time and then turn off. When the vehicle is unlocked, the indicator lights up again.



Function	Vehicle Status	Indicator Status	Color
Lighting	Charge port opened (no connector connected)	Solid white	
Charging	Charge/discharge initialization process	Flashing yellow	
	Charging being scheduled/charging paused	Solid yellow	
Charging	Charging in progress	Flashing green	
	Charging complete	Solid green	
Discharging	Discharging in progress	Flashing blue	
Fault	Charge/Discharge fault	Solid red	

Charging

- Before charging:
 - Check the charging device for abnormalities such as cracked housing, worn cable, rusted plug, or foreign materials.
 - Do not charge when the charging connection becomes loose.
 - Make sure the port is clear of fluids or foreign objects, and its metal terminals are not rusty or corroded.
- In any of these cases, do not charge. Otherwise, personal injury may occur due to short circuit or electric shock.

Using Mode 2 Charging Cable*

1. Equipment

- Connect the vehicle to an outlet that meets local standards to charge the vehicle.
- A household socket meeting local standards must be used in order to avoid line damage or tripping due to high-power charging, which may affect the normal use of other devices.
- This Mode 2 charging cable includes a power plug (complying with local standards), a charging connector, a control box, and a charging cable. Connect the plug to a standard household power socket, and the

charging connector to the vehicle's charge port.

- Charging time: Refer to the charging time message on the instrument cluster or infotainment touchscreen.

WARNING

- See "Charging Instructions" for charging safety warnings.
- The highest working temperature allowed for the product is 50°C. Store the product in a cool and dry place when it is not in use.
- When charging, do not place the equipment in the trunk, under the front of the vehicle, or near the tires.
- When using the equipment, prevent it from getting rolled over by the vehicle, dropped, or trampled on.
- Never drop the equipment or pull it directly by its cable. Take caution when moving the equipment.
- It is strictly prohibited to modify, disassemble, or repair the charging equipment and its ports.
- It is not recommended to use any additional wire or adapter/connector. If an additional adapter is required, choose a suitable cable diameter ($\geq 1.5 \text{ mm}^2$) and the adapter/connector parameters must meet requirements.
- Never use the charging equipment if the household power strip cable becomes soft, if the charging connector cable is worn out, if the insulation layer is cracked, or in case of any other damage.

WARNING

- Never use the equipment when the charging connector, power plug, or power strip is disconnected or broken, or if there is any sign of surface damage.

REMINDER

- It is recommended to contact a BYD authorized dealer or service provider or local electrician to select an appropriate power supply according to requirements of the charging equipment.
- Charging equipment grounding instructions: The equipment must be properly grounded. In the event of failure or damage to the equipment, the grounding cable provides a minimum impedance to circuit discharge and thereby reducing the risk of electric shock. The equipment comes with a ground cable connecting its ground point with that of the power plug, which must match a properly installed and well-grounded power supply outlet.
- The charging cable must not be placed in a spiral during charging, as this will affect heat dissipation.
- See the charging instructions for specific charging precautions.

2. Charging

Unlock the vehicle and open the charge port door.

- Open the charge port door:
 - With the vehicle doors unlocked and preferably powered off, press the charge port door to open it.



WARNING

- To prevent failure of the charge port door, do not open and close it repeatedly.
- Open the charge port cap, and make sure that no obstacles exist between the head of the charging connector and the end of the charging socket.



- Connect the power supply terminal:
 - Plug the Mode 2 charging cable into a household socket.
- Connect the vehicle port:
 - Plug the charging connector correctly into the port.
 - After the charging connector is inserted, the charging connection indicator on the instrument cluster or infotainment touchscreen lights up.
- In the charging process, charging parameters and the charging sign are displayed on the instrument cluster.

- At this point, you can schedule charging on the infotainment touchscreen. See **P87** for the configuration process.

3. Stopping charging

- End the charging:
 - The charging automatically ends when the vehicle is fully charged.
 - To end the charging early, proceed to the next step.
- Unplug the charging connector:
 - If the anti-theft mode of the electrical lock is deactivated, directly press the mechanical button of the charging connector and pull out the charging connector.
 - If the anti-theft mode of the electrical lock is active, press the unlock button on the key or press the microswitch on the door handle (when the key is nearby), then press the mechanical button of the charging connector to pull out the charging connector.

WARNING

- To unlock the vehicle, press the unlock button on the key (when charging the vehicle with ignition switched off) or press the microswitch on the door handle (when the key is nearby).
- When anti-theft is enabled, unlock the vehicle to release electrical lock of the charge port before pulling out the charging connector. The connector has to be pulled out within 30 seconds, or the port will re-lock.
- You can activate the anti-theft lock on the infotainment touchscreen, as detailed in **P88**.

⚠ WARNING

- If the charging connector cannot be removed after unlocking, try a few more unlocking attempts. If that does not work, try emergency unlocking. For the operating procedure, see **P89**.
- Disconnect the power plug.
- Close the charge port cap and the port door.
- Store the charging equipment properly.

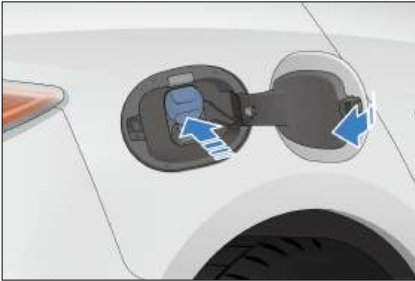
**! REMINDER**

- Do not close the charge port door when the port cap is fully open.

⚠ WARNING

- Never drop the Mode 2 charging cable or pull it directly by its cable. Take caution when moving the equipment. Store the equipment in a cool place after use.

Using AC Charging Piles**1. Equipment**

- Single-phase AC charging box*

- Use a standard-compliant household charging box. For how to use the charging equipment, refer to its user manual and follow the operating steps.
- The single-phase AC charging box consists of a charging box, a charging connector, and a connecting cable. For information on circuit breaker and emergency stop switch, see the charging box user manual.
- Single-phase AC charging pile
 - Charge the vehicle using an AC charging pile in a public place. Charging time: Refer to the charging time message on the instrument cluster or infotainment touchscreen.

2. Charging

- Unlock the vehicle and open the charge port door:
 - Unlock and open the charge port door according to the instructions for mode 2 charging.
- Connect the vehicle port:
 - Plug the charging connector into the port and lock it.
- Charging settings:
 - For AC charging pile/box subject to authentication, swipe the card or scan the QR code. See the user manual for charging pile/box for details.
- The charging connection indicator  lights up on the instrument cluster.
- In the charging process, the instrument cluster displays relevant charging parameters and the charging sign.

3. Stopping charging

- End the charging:

- Charging ends automatically when early stop time is due or charging is complete.
- Unplug the charging connector:
 - Disconnect as per the instructions for mode 2 charging.
- Close the AC charge port door (see instructions for Mode 2 charging).
- Store the equipment properly.
 - If using an AC charging pile/box, place the charging connector in its designated location in the charging pile/box.

Using DC Charging Piles*

1. Equipment

- Charge the vehicle using a DC charging pile in a public place, which is typically installed at a specific charging station.
- Charging time: Refer to the charging time message on the instrument cluster.
- Equipment specifications: Please check the instructions for the charger.

2. Charging

DC charging is achieved by connecting the vehicle to a DC charger via its connector.

- Unlock the charge port door, then open the port door and cap.
- Connect the vehicle port:
 - Plug the charging connector into the port and lock it.
- Operate the charging equipment to start charging.



- The charging connection indicator  lights up on the instrument cluster.
- In the charging process, the instrument cluster displays relevant charging parameters and the charging sign.

3. Stopping charging

- End the charging:
 - Charging ends automatically when early stop time is due or the charging is complete.
- Unplug the charging connector:
 - Press the mechanical lock button of the DC charging connector to pull out the connector.
 - Press the unlock button twice within three seconds or press the microswitch on the door handle to stop charging.
- When the DC charging pile charging is complete, organize the charging equipment and store the charging connector in its designated position properly.
- Reinsert the DC charge port cap and close the port door.

WARNING

- See section "Charging Instructions" for charging safety warnings.



⚠ CAUTION

- After charging, if the charging connector cannot be removed after unlocking, try a few more unlocking attempts. If that does not work, try emergency unlocking. For the operating procedure, see **P89**.
- To unlock the charge port after DC charging, press the unlock button twice within three seconds for the operation to be successful.
- See the charging instructions for specific charging precautions.

! REMINDER

- Do not close the charge port door when the port cap is fully open.

Reservation Charging

- The charging mode can be set on the infotainment touchscreen. To access the setting:
 - Go to infotainment touchscreen →  → **New Energy**. The reservation charging screen is displayed.
- To exit the Reservation Charging screen, tap  or .

Setting screen

- ① Reservation charging switch
- ② Charging start and end time
- ③ Repeat cycle
- ④ Settings



- The factory default setting is to charge the vehicle immediately. That is, scheduled charging is disabled.
- To schedule a charging, toggle the reservation charging ON ①, set the charging start and end time ② and repeat cycle ③, then save the settings.
- After the schedule is set up successfully, if you connect the charging connector or press the power button to power off the vehicle during the charge waiting period, you will be reminded through the infotainment touchscreen that scheduled charging has been set. Switch to instant charging if needed.
- You can tap the reservation charging setting icon ④ to turn off the charging connector connected alert and power-off alert in the **Reservation Charging Alert**.

⚠ CAUTION

- The reservation charging function is developed for BYD's slow AC charging equipment only. Please disable this function when using slow AC charging equipment that is not certified by BYD. Otherwise, scheduled or immediate charging may fail due to no response from the equipment, resulting in low SOC or even low voltage of the high-voltage battery.

! REMINDER

- The instant charging option on the reminder screen is valid for the current reservation only. To cancel all reservations, toggle charging reservation off on the corresponding setting screen.
- In the event of low battery, the vehicle is charged to the minimum level before scheduled charging begins. In this process, the infotainment system still gives reminder messages for power-off and charging connector connection, and a related message is displayed at the lower part of the instrument cluster.
- The schedule setting is invalid for DC charging. Charging begins immediately after a DC charging connector* is connected.
- The vehicle's power will increase while waiting for the reservation charging. It is normal for long waiting to result in a reduction of the vehicle's SOC and driving range.

Intelligent Charging

- This model is provided with the intelligent charging function. It is not necessary to disconnect the low-voltage battery's negative terminal when the vehicle is to be parked for a long period.
- When the low-voltage battery manager detects that the battery level is too low, the low-voltage battery can be charged with the high-voltage battery.

! REMINDER

- When the vehicle is stored for a long time, the intelligent charging

! REMINDER

- function may be activated, which is normal and not a vehicle failure.
- Power for intelligent charging comes from the high-voltage battery pack, so it is normal that an SOC decrease is noticed when the vehicle is powered on.
- To avoid high-voltage battery over-discharging due to intelligent charging, when the vehicle is at low SOC, intelligent charging function is unusable. Avoid parking at low SOC for a long time, and charge the vehicle in time.

Charge Port Anti-theft Lock

In order to prevent the charging connector from being stolen, the charge port of this vehicle is anti-theft during charging and discharging. The anti-theft function is disabled by default. To enable the function, go to the infotainment touchscreen →  → **New Energy** → **Charging Settings** and then tap **Enable**.

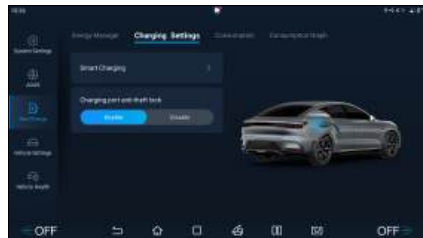

- When the function is enabled, unlock the vehicle and unplug the charging connector during charging in the following ways:
 - Press the unlock button on the smart key to unlock.

- Press the microswitch next to the exterior handle of the driver's side door to unlock.
- Press the central unlock button under the driver's window to unlock.
- As shown in the table below, if the vehicle is in state 2/3/4, apart

from the above-mentioned unlocking operations, you can unlock and pull out the charging connector by pressing its button. However, this may affect the service life of the charge port or charging connector. This is an emergency action that is not recommended to take frequently.

No.	Charge Port Anti-theft Lock Status	Door Anti-theft Lock Status	Charging Connector Removable or Not
1	Enabled	Locking	No
2	Enabled	Enabled	Yes
3	Disabled	Locking	Yes
4	Disabled	Enabled	Yes

! REMINDER

- Unplug the charging connector in 30 seconds after unlocking or it will be locked again.
- When the anti-theft mode is disabled, the electrical lock of the charge port automatically releases once the charging is stopped. When the anti-theft mode is enabled, the vehicle needs to be unlocked first.

Emergency Unlocking of the Charge Port

When the charging connector cannot be unplugged due to failure of the anti-theft lock, unlock the charge port manually and unplug the charging connector.

1. Open the trunk. There is an emergency cable for the charging connector on the right side panel inside the trunk.
2. Unlocking the cable latch and pulling the emergency cable to unlock the charging connector.

3. Reset the emergency cable latch after the unlocking is complete.

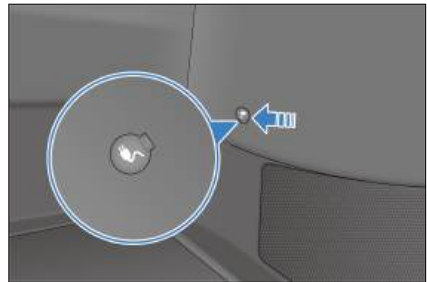

! REMINDER

- In the event of abnormality or function failure, contact a BYD authorized dealer or service provider.

External Discharging

- This vehicle features a discharging function: vehicle to load (VTOL) function.

WARNING

- Do not touch any metal terminal of the discharge power strip, in-vehicle discharge socket, or vehicle charge port during discharging.
- Stop discharging immediately if there are any abnormalities such as peculiar smell and smoke.
- See Charging Instructions for charging safety warnings.
- Store the product in a cool and dry place when it is not in use.
- When discharging, do not place the equipment in the trunk, under the front of the vehicle, or near the tires.
- When using the equipment, prevent it from getting rolled over by the vehicle, dropped, or trampled on.
- Never drop the equipment or move it by pulling it directly by the cable. Take caution when moving the equipment.
- Never use the equipment if the power strip cable becomes soft, if the discharging connector cable is worn out, if the insulation layer is cracked, or if any other damage occurs.
- Never use the equipment when the discharging connector or power strip is disconnected or broken, or when there is any sign of surface damage.

CAUTION

- For precautions concerning use of the discharge connection device,

CAUTION

- please refer to the precautions for charging equipment in **P79**.
- Before discharging, please confirm the vehicle SOC and estimate the remaining driving range.

REMINDER

- The V2L function is recommended only when SOC is high.
- The V2L function is restricted when the vehicle SOC is low.

External Discharging Method*

Starting discharging

- Before discharging, disarm the anti-theft alarm system.
- Unlock the charge port door switch, then open the port door and cap.
- Check before discharging:
 - Ensure that the battery capacity of the vehicle to be discharged is not below 15%.
 - Ensure the V2L connection device casing is not cracked, and its plug is free from rust or obstructions.
 - Ensure that there is no water or foreign material inside the charge port and that metal terminals are not damaged and free from rust or corrosion.
 - Do not discharge if any of the above conditions is found; otherwise, short circuit or electric shock so caused could lead to personal injury.
- Connect the discharge connection device:

- Connect the V2L discharge device to the charge port. The power strip indicator lights up when the strip is powered and ready for use.
- Discharging starts:
 - After the connection is made, discharge begins and respective information is displayed on the instrument cluster.

Stopping discharging

- Stop discharging:
 - Disconnect the load.
- Disconnect the discharge connection device:
 - Unplug the discharging device.
 - Close the charge port cap and the port door (see **P82**).
- Organizing the equipment:
 - Store the equipment properly when discharging is complete.

Driving Range Display

- The range display mode can be set to improve driving experience. The default setting is standard mode.
- The corresponding settings can be made in infotainment touchscreen
→  → **New Energy** → **Energy Manager** → **Range display mode**.
 - Standard mode: displays the driving range based on the result of comprehensive working condition test.
 - Dynamic mode: displays the estimated driving range based on the available battery power and current average energy consumption.
- The set driving range display mode is memorized by the system.

- When the vehicle is powered off and then on, the display mode set last time will be maintained.

REMINDER

- When the Dynamic driving range display mode is set:
 - The driving range that is displayed after a full charge may vary, depending on calculations of the energy consumed the last time the vehicle is used.
 - The driving range actually displayed will be adjusted based on the state of the vehicle's air conditioner, the driving mode (ECO, NORMAL, SPORT, etc.) selected, and the driver's driving habits, so as to match the vehicle's actual driving range.

Battery

High-Voltage Battery

- The vehicle is powered by a high-voltage battery that can be charged and discharged repeatedly. The high-voltage battery is charged by an external power source or through energy recovery when the vehicle brakes or coasts.
- The high-voltage battery is located under the vehicle floor, so be careful to avoid bumping when driving on bumpy or uneven roads.

Battery Properties

- The charging and discharging power of the high-voltage battery is related to the state of the battery pack, which is mainly affected by its SOC and the temperature of the battery cell.

- It is normal that vehicle performance is affected by battery electrochemical properties and self-protection and varies to some extent in the following conditions:
 - When SOC is high, the regenerative braking performance may decline.
 - The vehicle switches to trickle charging mode and the charging power is reduced at high SOC. If the charging time is prolonged, the estimated remaining charging time displayed on the instrument cluster may not be accurate.
 - When SOC is low, the acceleration performance may decline.
 - When the high-voltage battery is low, V2L cannot be used as normal. Charge the battery promptly.
 - At high or low temperatures, it is normal that the charging and discharging capabilities of the high-voltage battery decline, and the charging time is prolonged. Power performance may also decline under extreme temperatures.
 - When charging at low temperatures, the temperature control system can significantly improve the charging capability. For details regarding low-temperature charging, see Charging Precautions.
 - When the vehicle is used at low temperatures, the battery's temperature control system will start heating the battery as appropriate to ensure the driving power and discharging performance and improve your driving experience. When the vehicle is driven over short distances, heating may be ineffective, which increases power consumption and decreases driving range.
- When the high-voltage battery is normal, the driving range of the vehicle varies with the following factors:
 - Driving habit: For example, the range in frequent acceleration or deceleration is shorter than that at constant speeds, and the range is shorter when driving at high speeds than when at low speeds.
 - Road conditions: For example, the range driven in rough conditions or on long slopes is shorter than that in normal conditions and on even roads.
 - Temperature: The driving range at low temperatures is shorter than that at ambient temperatures.
 - Use of electric equipment: For example, the range driven with A/C on is shorter than that with A/C off.
 - Usable capacity of the high-voltage battery is lower in cold weather and reduces as the temperature decreases. If the vehicle with high battery level is charged at low temperatures, the SOC may quickly jump to 100%.

Battery usage tips

- It is recommended to use the vehicle at temperatures between -10°C to 40°C. When SOC is low, timely charge the vehicle to ensure enough driving range and good acceleration performance.
- When a high speed is required and the ambient temperature is low, it is recommended to drive at high SOC to ensure good acceleration.
- Do not park the vehicle in a place above 40°C for a long time (more than 15 days), or it will reduce high-voltage battery service life.
- Frequent and sudden acceleration or deceleration should be avoided. Drive

the vehicle on flat and dry roads. When necessary, turn off high-power equipment such as A/C or adjust the A/C temperature to reduce power consumption of such devices and increase the driving range.

- Low-power charging contributes to the service life of high-voltage battery.
- In low temperatures, it is recommended to charge the vehicle immediately after each driving to ensure high charging power for fast charging.
- When the vehicle is used for the first time or after a long idle period, the SOC displayed on the instrument cluster may not be correct. It is recommended to fully charge the vehicle first.
- It is recommended to fully charge the vehicle at a regular basis (at least once a week), and fully charge it from low battery (SOC <5%) once every three to six months. When SOC is below 10%, it is recommended to discharge the vehicle to below 5% by using A/C, infotainment system, and other low-voltage devices with P gear engaged.
- Under extreme working conditions (such as frequent sudden acceleration/ deceleration) that cause battery overheating, if the temperature of high-voltage battery is excessively high, it is normal for discharging capability to decrease gradually. If the battery temperature keeps rising, the fault warning light lights up on the instrument cluster. In that case, it is recommended to contact a BYD authorized dealer or service provider.
- When the battery SOC increases or decreases abnormally, it is recommended to contact a BYD authorized dealer or service provider for inspection.

 **WARNING**

In the event of an emergency or accident, be aware of the following warnings:

- To avoid personal injury, do not touch the high-voltage battery directly.
- Please contact a BYD authorized dealer or service provider as soon as possible.
- If the high-voltage battery is damaged and leaking fluid, avoid any contact with the fluid. If it comes into contact with skin or eyes, rinse immediately with plenty of water, and seek immediate medical attention.
- If the vehicle catches fire, use dedicated fire extinguishers instead of water-based fire extinguishers.

 **CAUTION**

- To ensure safety of the high-voltage battery, stop the vehicle away from flammable and explosive materials, ignition sources and various hazardous chemicals.
- The available battery capacity decreases as the vehicle is used over time.
- Prolonged exposure to heat sources and direct sunlight can reduce the service life of the high-voltage battery.
- If there is a collision with the high-voltage battery, contact a BYD authorized dealer or service provider immediately for maintenance.

High-Voltage Battery Recycling

How to scrap an NEV:

1. Take the vehicle to the BYD recycling service provider that will assess the residual value of the high-voltage battery.
2. Take the assessed vehicle to the recycling organization to disassemble the high-voltage battery.
3. Take the battery to the recycling service provider which will buy back the battery.

WARNING

- New energy car owners have the responsibility and obligation to hand over waste high-voltage batteries to the recycling service outlet. Anyone who hands over a used high-voltage battery to any other organization or individual, or removes/disassembles a high-voltage battery without authorization, shall be liable for any environmental pollution or safety incident so caused.

Low-Voltage Battery

- Battery working modes include "Normal", "Sleep", "Ultra-low Power" and "Low-Voltage Protection", which helps to protect the battery cell from damage. If the vehicle system is in good condition, the working modes switch automatically and cause no effect on your vehicle.
- To avoid low-voltage battery feed, the intelligent charging function will be actively triggered if conditions (hood closed, ignition "OFF", high-voltage battery discharging allowed, and low-voltage battery level lower than the design value) are met.

- When the intelligent charging function is triggered, the low-voltage battery is charged through the high-voltage battery. Therefore, it is normal that the SOC or the pure-electric driving range displayed on the instrument cluster decreases, when the vehicle is started after being idle.
- If intelligent charging fails, the low-voltage battery may cut off the vehicle's power supply. If you find that the vehicle is not powered before use, try to activate the low-voltage battery by pressing the driver door microswitch continuously, and immediately power on the vehicle to charge the low-voltage battery. It is recommended to charge it for more than one hour.

CAUTION

- The low-voltage battery contains relays. Thus, it is normal that relay operating sounds may be emitted from the battery.
- The low-voltage battery shall be charged with professional charging tools, and shall not be removed for recharging without permission.
- Do not jump-start the vehicle with another vehicle, as this may damage the low-voltage battery.
- The low-voltage battery has a built-in power manager. Do not disassemble or repair the battery without permission to avoid damaging the battery or causing personal injury.
- The low-voltage battery needs to communicate with the vehicle for normal use, so it is important to connect its connector and wiring harness correctly.

Usage Precautions

Break-in Period

- If the powertrain is hard to start or frequently stops turning, inspect the vehicle immediately.
- If the powertrain makes any abnormal sounds, stop the vehicle for inspection.
- If the powertrain has severe coolant and oil leakage, stop the vehicle for inspection.
- The powertrain needs break-in. This should preferably be done within the first 5,000 km in economic mode. Steady driving instead of high-speed driving is recommended. The following practices effectively prolong vehicle service life:
 - Avoid flooring the accelerator pedal when starting and driving the vehicle.
 - Avoid speeding.
 - Avoid emergency braking within the first 300 km.
 - Do not maintain a high or low speed for too long.

Trailer Towing

- This vehicle is designed to carry passengers. Do not overload it or use it to tow other vehicles.
- Towing other vehicles has an adverse impact on the maneuverability, performance, braking, endurance, driving economy, power consumption, and other aspects of performance of the vehicle itself.
- Driving safety and comfort totally depend on equipment usage and good driving habits.

- BYD does not provide free warranty for the damage or faults resulted from the trailer towing.

Saving Energy and Extending Vehicle Service Life

- Saving energy is simple and easy, and it helps prolong the vehicle's service life.
- Here are some tips for saving energy and repair cost:

1. Regenerative braking setting:

- The vehicle is provided with an energy regeneration function. To set the energy regeneration intensity, operate the regenerative braking mode button or go to the infotainment touchscreen. In high energy recovery mode, more energy is recovered during vehicle braking and coasting. Please set to suit to your driving habits.

2. Maintaining constant speed:

- Constant speeds save energy. Sudden acceleration, sharp turns and emergency braking increase consumption.
- Speeds should be kept constant according to traffic conditions. Additional energy is consumed each time the accelerator is pushed.
- Acceleration should be gradual. Avoid sudden startup, acceleration, or deceleration.
- Prevent emergency braking, and subsequent brake wear, by keeping an appropriate distance from vehicles ahead, and paying attention to traffic lights.
- Congested roads increase energy consumption.

- Keep moderate speeds in motorways. The higher the speed, the higher the consumption. Maintaining vehicle speed within the economical speed range can save power.

3. Reducing load:

- Consumption is higher when air conditioning is used. Turn off the A/C to reduce power consumption. When outside temperatures are moderate, use fresh air mode.
- Do not overload the vehicle unnecessarily. Excessive weights will add the load of vehicle, increasing energy consumption.

4. Other tips:

- Make sure tire pressure is correct. Low tire pressure increases energy consumption and wear.
- Keep front wheels properly aligned, avoid driving into curbstones, and drive slowly in rough terrain. Misalignment of the front wheels not only increases tire wear, but also increases load on the powertrain and power consumption.
- Keep the bottom of the vehicle clean and mud free. This reduces vehicle weight and prevents corrosion.

REMINDER

- Do not coast in neutral gear.

Carrying Luggage

- This vehicle has multiple storage spaces. Overloading or improper accommodation may affect maneuverability, stability and normal operation of the vehicle, and reduce its safety.
- Make sure the vehicle's total load (vehicle + passengers + luggage)

remains within the specified maximum weight.

WARNING

- Overloading and improper accommodation may affect stability and vehicle control, which may lead to accidents.
- Observe the maximum weight limit and other loading guidelines in this manual.
- Do not carry highly magnetic items, as they might interfere in the vehicle's normal operations.

Carrying Items in the Passenger Area

- All items that could be thrown inwards and thus injure occupants in case of a collision must be properly placed and secured.
- Ensure that items placed on the floor behind the front seat do not roll under the seat, so as to avoid affecting the driver's ability to control the pedals or normal seat adjustment. Do not stack items to a height taller than the front seats' seat backs.
- Make sure the glove box is always closed while driving. If the glove box is open, the occupant's knees may be injured in case of a collision or an emergency stop.

REMINDER

- Do not pile up toys in the vehicle, as this may affect driving safety and present a hazard to the children, especially in case of emergency braking or collision.

Loading the Trunk

- Place luggage evenly in the trunk. Put heavier items at the bottom and as far in as possible.
- Secure items with ropes or straps so that they will not move while driving. Do not stack items to a height taller than seatbacks.
- For trunk strapping or fastening supplies, contact a BYD authorized dealer or service provider.

Wading into Water

- Check water depth - it must not exceed the vehicle's lower edge before driving into flooded areas.
- If crossing a flooded area is necessary, turn off the air conditioner and keep acceleration steady to slowly cross over.



- Never stop, back up, or turn off the vehicle in flooded areas.
- After crossing over, press the brake pedal several times to dry out the disks and recover brake performance.
- Be careful when driving through deep water, as brakes may get wet.

WARNING

- The presence of water, mud, or silt in the braking system may delay brake response and extend braking distance.
- Drive carefully and avoid emergency braking after crossing flooded areas.
- The motor will be seriously damaged if it is submerged when crossing a flooded area. Such damaged is not covered by the vehicle's warranty
- Other systems like transmission, driving and electrical systems may also be seriously damaged upon submersion. Such damage is not covered by the vehicle's warranty either.

Influence of water ingress in high-voltage components:

- Water getting into high-voltage components, which are electronic devices, may not be fully dried out by any means.
- Water ingress seriously compromises insulation of high-voltage components, and conductive substances in water may lead to short circuit of high-voltage components or such risk in the entire high-voltage system. This significantly affects the safety and service performance of the vehicle.
- The reduced ingress protection rating and voltage withstanding performance due to water in high-voltage components pose a high safety risk.
- Be sure to find a sheltered place when charging the vehicle on rainy days. If the vehicle is immersed in water or wades through water over

the doorsill, which may cause water ingress in high-voltage components, promptly contact a BYD authorized dealer or service provider for testing and troubleshooting. Do not drive on roads where the depth of accumulated water exceeds half of the tires.

Fire Prevention

To prevent vehicle fires in a timely and effective manner, pay attention to the following during use of the vehicle:

- No flammable or explosive items are allowed in the vehicle.
 - Temperatures may reach 60-70°C in a vehicle exposed to direct sunlight in summer. Therefore, flammable and explosive items, such as lighters, cleaning agents and perfumes, stored in the vehicle can cause a fire or even explosion easily.
- Make sure cigarettes are thoroughly put out.
 - Smoking is harmful to your health and may cause a fire. Cigarettes that not thoroughly put out may cause a fire.
- It is recommended to go to a BYD authorized dealer or service provider for regular vehicle checks.
 - Check vehicle wiring, connections, wiring harnesses, insulation, and fixed position regularly. Deal with identified problems promptly.
- Do not refit vehicle wiring or add any unauthorized electrical appliance.
 - The addition of extra electrical appliances, such as high-power audio systems, and light fixtures, may overload and overheat the wiring harness and increase the risk of fire.
- Improper refitting of electrical appliances or wiring may cause a fire due to contact resistance and abnormal heating. Other replacement wires or fuses in excess of relevant electrical rating are strictly prohibited.
- Select a proper parking location.
 - When parking the vehicle, try to avoid sun exposure.
- Keep a lightweight fire extinguisher in the vehicle and know how to use it.
 - In order to ensure vehicle safety, a fire extinguisher should be equipped in the vehicle, and be checked and replaced regularly. Also, you should familiarize yourself with use of the fire extinguisher and be prepared for any accidents.
- Disconnect the negative cable of the low-voltage battery when the vehicle is being serviced or repaired.
- In the event of a fire in the vehicle, take effective measures in a timely and calm manner to minimize any losses:
 - Fires typically show initial warning signs, such as abnormal noises and odors in the vehicle body. When abnormal conditions are found, turn off and stop the vehicle immediately. It is best to park the vehicle in a windproof place, and then put out the fire using the fire extinguisher in the vehicle.
 - Call the fire alarm in time, and also dial the insurance company's reporting number and ask the company to come to the fire site for handling.
 - Look for the ignition point. If the cabin is smoking, do not open the hood immediately. (Doing so will let a large amount of air in and cause fire spreading. There is limited comburent in the cabin. Keeping the

hood closed can control the fire so that the fire can be easily put out). Point the on-board fire extinguisher at the ignition point from the hood gap to put the fire out, or seek help from the passing cars. If you can borrow more fire extinguishers, open the hood to put it out when you cannot see any flame from outside.

- If the fire brigade is involved, ask for a duty performance certificate and a description of fire cause.
- After occurrence of the accident, contact the insurance company for post-event handling in a timely manner.

REMINDER

- In order to mitigate losses in the event of an accident, the purchase of commercial insurance (fire loss, theft, etc.) is recommended.

Starting and Driving

Starting the Vehicle

In normal cases, start the vehicle as below:

- Engage the parking brake firmly.
- Shift to Park or Neutral.
- Carry the correct smart key with you.
- Press the power button ② while pressing the brake pedal ①.



- The vehicle is ready to drive when the OK indicator lights up on the instrument cluster.

The vehicle cannot power on when

- The vehicle cannot power on when:
 - After you press the START/STOP button, the smart key warning light turns on, a beep sounds, and the message "No key detected" is displayed on the instrument cluster. This means that the key is not in the vehicle or cannot be detected due to interference.
 - The key is somewhere unsuitable for detection, such as on the floor, in the cup holder, trunk, or storage compartment.

Starting the vehicle in emergencies:

- Engage the parking brake firmly.
- Turn off all unnecessary lights and accessories.
- Switch the ignition off.
- The electronic smart key is in the vehicle.
- Press and hold the smart key start button for over 15 seconds.

CAUTION

- Do not touch the power button while driving.

Remote Start*

Before starting

1. The power mode is "OFF".
2. The gearshift lever is on "P".
3. The vehicle speed is below 5 km/h.

Remote Start with the Electronic Smart Key

1. Press and hold the remote start/stop button on the electronic smart key for two seconds to start the vehicle. After it is started, turn signals will flash three times.
2. If there is no valid operation within 10 minutes after remote start, the vehicle stops and powers off, and turn signals flash twice.



3. After the vehicle is started, pressing and holding the remote start/stop button on the smart key for two seconds switches the ignition off. The turn signals then flash twice.

Driving

- During driving, energy is recovered through regenerative brakes when the vehicle decelerates. For higher efficiency, do not accelerate or decelerate the vehicle unnecessarily.
- The energy feedback intensity can be made in infotainment touchscreen

→  → **New Energy** → **Energy Manager**.

- Standard: When the accelerator pedal is released, the motor controller recovers energy in the standard level, and the vehicle deceleration is in the standard level.
- High: When the accelerator pedal is released, the motor controller recovers more energy, and the vehicle deceleration is high.
- You can select the regeneration intensity based on the deceleration sense when releasing the accelerator pedal. Different deceleration senses deliver different driving experiences.
- The set energy regeneration intensity will be memorized. When the vehicle is powered off and then on, the regenerative braking mode set last time will be maintained.



REMINDER

- Do not set the regeneration intensity when driving the vehicle in high speed, as the driver may be distracted. This may obstruct the control of the vehicle, resulting in accidents.
- The driving modes are ranked as SPORT, NORMAL, and ECO, in descending order of driving power. Be sure to drive safely.
- The power of the whole vehicle is weaker at low battery level than that at high battery level.

Safety Check Before Driving

It is advisable to carry out a safety check before driving long distance, which ensures your driving safety and enhances your driving experience. The vehicle can

also be taken to a BYD authorized dealer or service provider for inspection.

Exterior

- **Tires:** Check tire pressure and carefully inspect tires for any cut, damage, foreign material, anomaly, and excessive wear.
- **Lug nuts:** Ensure all nuts are fitted and tightened.
- **Lighting:** Make sure headlights, parking lights, position lights, turn signals and all other lights are working normally. Check headlight intensity.

Interior

- **Seat belts:** Check whether seat belts can be properly fastened. Verify that seat belts are not worn or scratched.
- **Instrument cluster:** Particularly, verify that maintenance indicator, instrument cluster lighting, and defroster work properly.
- **Brake pedal:** Verify that there is enough space for the brake pedal to work.

In the engine compartment

- **Spare fuses:** Verify that spare fuses of all rated charges in the fuse box are available.
- **Coolant level:** Verify that coolant level is correct.
- **Low-voltage battery and cables:** Check connectors for any corrosion or looseness and any cracks in the low-voltage battery housing.

Check after starting

- **Instrument cluster:** Confirm that the maintenance indicator and the speedometer work normally.
- **Brakes:** In a safe area, drive the vehicle straight, hold the steering wheel tightly, decelerate and apply the

brake. Verify that the vehicle maintains a straight direction.

- **Other abnormalities:** Check for loose parts, leaks, and unusual noises.

Preparations Before Driving

- Check the surroundings before getting into the vehicle.
- Adjust seat position, seatback angle, cushion height, headrest height, and the steering wheel angle and height.
- Adjust interior rearview mirror and side mirrors.
- Close all doors.
- Fasten the seat belts.

Gear Shift Controls

- The gear shift marks are on the gearshift lever as shown.
- "P": Parking. Press this button to park the vehicle. Shift to this position when turning the motor on or off.
- To start the vehicle, turn the ignition on. Press the brake pedal and the UNLOCK button ①, and toggle the gearshift lever to switch from "P" to another position.

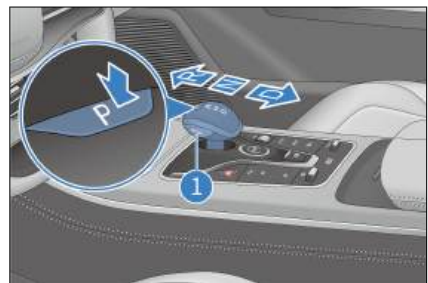

CAUTION

- To prevent damage, press the "P" button only after the vehicle has completely stopped.
- "R": Reverse, used only when the vehicle has come to a complete stop.
- "N": Neutral, used for temporary stop.
 - Under all circumstances, always shift to "P" before the driver gets out.
- "D": Drive. Shift to "D" to drive the vehicle normally.
- Turn the ignition on before shifting into "D".
- Shifting out of "P" or into "D" gear requires pressing the brake pedal and the UNLOCK button at the same time. For details, see the prompt message on the instrument cluster.
- If the shift is successful, the lever returns to its middle position automatically after it is released.

WARNING

- If the motor is turned off and the vehicle travels for a long time in the "N" gear, the gearbox may be severely damaged due to lack of lubrication.
- When the motor is running and the vehicle is in the "R"/"D" gear, always stop the vehicle by stepping on the brake pedal, as there is still force transmitted from the actuator and the vehicle can travel slowly even in its idle condition.
- If you want to shift a gear while driving forward, do not step on the accelerator pedal to prevent accidents.

WARNING

- Never shift to "R" or press the "P" button while the vehicle is moving, in order to prevent accidents.
- It is not recommended to allow the vehicle to go down a ramp when it is in the "N" or "P" gear, even if the vehicle is not started.
- To prevent unintended vehicle movement, press the "P" button once the vehicle has stopped completely. The electronic parking brake (EPB) is automatically applied and the EPB indicator lights up.

Electronic Parking Brake (EPB)

EPB Switch



- Be sure to engage the Electronic Parking Brake (EPB) every time before parking and leaving the vehicle.



Engaging EPB Manually

Pull up the EPB switch. EPB applies an appropriate parking force, and  flashes on the instrument cluster and then becomes solid on, indicating that EPB has been applied. The "EPB activated" message is also displayed.

CAUTION

- When  flashes, EPB is working. If the vehicle is on a slope, do not release the brake pedal until  is steady on. Otherwise the vehicle may move down.

Engaging EPB Automatically

Engaging EPB automatically when the ignition is switched off

- When the ignition is switched off, EPB engages automatically and  lights up on the instrument cluster.

Engaging EPB automatically when shifting into "P"

- Press the brake pedal to stop the vehicle and shift into Park. EPB is engaged automatically. Do not release the brake pedal until the indicator on the instrument cluster stops flashing and becomes steady on and the "EPB ON" message is displayed.

CAUTION

- The EPB is not automatically engaged if you switch off the ignition immediately after pressing the EPB switch. This function may be used for towing or pushing the vehicle after the vehicle breaks down.
- Do not release the brake pedal early in the process, especially when the vehicle is stopped on a slope; otherwise the vehicle may slip back.
- This function is designed to improve vehicle safety. Excessive reliance on or frequent use of the function is not recommended. For safety reasons, make sure that the vehicle is shifted into "P" or the EPB is engaged before getting off.

CAUTION

- The EPB system conducts power-up self-check within several seconds after the vehicle is started. In this process, the system does not respond to any function.

Releasing EPB Manually

- When vehicle has been powered on and is not shifted into P (Park), press and hold the brake pedal and the EPB switch until the indicator on the instrument cluster goes out, indicating EPB has been released, and an "EPB released" message is displayed.

CAUTION

- The P gear is the vehicle's parking gear, meaning that the vehicle is in a stable parking status, while EPB is the vehicle's main parking device. To ensure parking safety, release EPB with the EPB switch only when the vehicle is not in P gear (parking gear).

Automatic EPB Release upon Vehicle Start

- With the vehicle parked, start the vehicle, press and hold the brake pedal, and shift from "P" or "N" into a driving gear such as "D" or "R". EPB is released automatically, the indicator goes off, and the "EPB released" message is displayed.

CAUTION

- Be sure to always press and hold the brake pedal when shifting gears. Release the pedal only after the intended gear is displayed on the instrument cluster.

- When the vehicle has been started and the gear is in a driving gear such as "D" or "R", engage EPB manually, then simply press the accelerator pedal slowly to a certain degree. EPB is released automatically and (P) turns off with the message "EPB released" displayed.

WARNING

- For safety considerations, refrain from using EPB for braking in normal driving. It is preferred to be used when the brake pedal fails or is blocked.
- As the EPB cannot go beyond the physical limit of road adhesion, activating the emergency brake function may result in vehicle drift, sideslip, or deflection when the vehicle passes through bends or dangerous/heavy-traffic road sections, or when the vehicle is driven under severe weather conditions. Be careful to avoid any possible accident.

If EPB Release Fails

- If manual EPB release fails, press and hold the EPB switch for over two seconds. If EPB can be released, drive the vehicle to the nearest repair shop to check the brake pedal switching signal and relevant parts and lines. If it cannot be released, contact a BYD authorized dealer or service provider immediately.

Emergency Braking When Brake Pedal Fails

- When the vehicle is in motion and ESC system is functional, controlled deceleration for parking brake (CDP) can be used if the brake is stuck or fails. If only EPB is engaged, the

braking deceleration is 0.4 g; if EPB is engaged and the brake pedal is pressed, the braking deceleration is 0.8 g. Avoid using EPB for forced braking, but only activate emergency braking in case of emergencies such as brake pedal failure or sticking.

EPB System Indicator

- When the vehicle is powered on, if the EPB is engaged, (P) is solid on the instrument cluster.
- When the vehicle is powered off, if the EPB is engaged, (P) comes on and then turns off in about three seconds.
- When the vehicle is powered on, the EPB system starts self-check. (!) turns on and then turns off in about three seconds. If it does not, the EPB or braking system may be faulty. In this case, contact a BYD authorized dealer or service provider immediately.

EPB Operating Sound

- EPB motor noises can be heard while the EPB is being engaged or released.
- If there is a burning smell or unusual noise after emergency braking is activated, contact a BYD authorized dealer or service provider immediately.

WARNING

- To prevent the vehicle from moving, do not the replace EPB with the gearshift when parking. EPB must be used instead, and the vehicle must be in "P" gear.
- To prevent a serious accident, never allow any passenger in the vehicle to operate the EPB switch when the vehicle is running.

WARNING

- When the EPB switch is pulled or released, the brake pedal must be pressed to prevent the vehicle from moving, and the subsequent locking of the gearshift that occurs because EPB cannot provide a sufficient parking force.

Automatic Vehicle Hold (AVH)

Auto Vehicle Hold (AVH) takes place when the vehicle needs to be stationary for longer periods of time, such as in traffic jams on a slope or waiting at traffic lights. When the AVH standby preconditions are met, AVH is activated if you press the brake pedal until the vehicle stops.

- Press the AVH switch to enable AVH. A white AVH standby indicator is displayed on the instrument cluster and will turn green when AVH can be enabled.
- Press the AVH switch again to disable AVH.

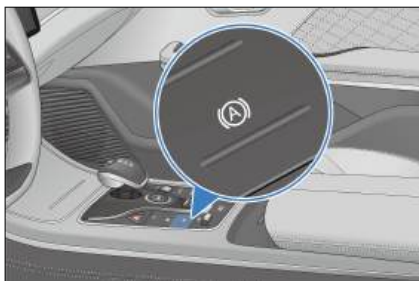

CAUTION

- Pressing the accelerator pedal, shifting into Park, or engaging the EPB can make AVH exit to the standby status. The vehicle exits

CAUTION

AVH mode even if the AVH standby conditions are not met.

AVH Standby Preconditions (All Must Be Met)

- AVH switch is turned on and the white AVH standby indicator is displayed on the instrument cluster.
- The driver seat belt is fastened and the doors are closed.
- The vehicle drive motor is started or the ignition is on.
- The ESC and EPB systems have no fault.

CAUTION

- The AVH defaults to off once the vehicle is powered up. When AVH is in standby mode, the white AVH standby indicator is displayed on the instrument cluster.

AVH Running Conditions (All Must Be Met)

- The AVH function is standby.
- In D gear, the brake pedal is pressed to stop the vehicle.
 - The AVH function is enabled, brake lights and the high mount brake light are on, and the AVH indicator on the instrument cluster turns green.
 - The AVH function enters the standby mode after working for 10 minutes, with the EPB automatically engaged.
- For AVH to be activated, all the conditions must be met at the same time.

CAUTION

- For AVH to be activated, all conditions of automatic parking function must be met.
- When the gear is shifted from D to R, the system enters the slow-moving conditions, in which AVH is deactivated. When the AVH button is pressed or the speed exceeds 10 km/h, it exits the slow-moving condition.

Slow-Moving Conditions

- When the gear is shifted into Reverse and the vehicle moves slowly, AVH goes into slow-moving condition. When the vehicle is reversing (R gear) or traveling (D gear) at a low speed, AVH is suppressed to improve vehicle motion.
- To exit slow-moving mode, push the AVH switch or drive at a speed above 10km/h. Then the AVH function can be activated normally.

Driving Precautions

- Drive slowly and carefully along gravel roads. To prevent tire damage, do not drive over sharp-edged obstacles.
- Slow down on bumpy or uneven roads. Otherwise, the impact may seriously damage wheels.
- Avoid driving through flooded areas as much as possible.
- Slow down when driving against strong winds.
- Cleaning the vehicle or driving through deep water may wet brakes. To keep brakes dry, drive carefully and press the brake pedal gently.

- Drive carefully on slippery roads, such as roads covered in ice, snow or sand, or surfaces such as wet ceramic tiles or epoxy resin. Avoid parking on slopes to prevent vehicle sliding.

WARNING

- The high-voltage battery is located in the vehicle's chassis. Make sure to avoid bumping when driving.
- The driver shall ensure the riding safety of all passengers in the vehicle, guide them to correctly use vehicle features, and prevent children and other passengers operating in a wrong way.
- Make sure no occupant sticks their head or hands outside the vehicle, specially when it comes to children.
- Be careful when accelerating or braking on slippery roads. Quick acceleration or sudden braking will cause the vehicle to skid or deviate.
- Do not leave the vehicle with ignition on.
- Remember to carry the smart key when leaving the vehicle.

CAUTION

- Before driving, make sure that EPB is fully released and that the EPB indicator light is off.
- Slow down when driving down steep slopes, and avoid braking too frequently to prevent disc overheating, which affects brake performance.
- Large amounts of water entering the engine compartment



CAUTION

can cause damage to the power system and electrical components.

Winter Driving Precautions

1. Make sure the coolant is freeze-proof.
 - Use coolant of the same type as the one used originally. Fill up coolant into the cooling system based on ambient temperature.
 - Improper coolant damages the cooling system.
2. Check batteries and cables conditions.
 - The low-voltage battery's capacity is lower in cold weather, so they must be fully charged when winter comes.
3. Avoid door frost.
 - Spray some deicing agent or glycerin in the lock hole to prevent freezing.
4. Use anti-freeze washer fluid.
 - These can be found in the BYD authorized dealer or service provider and the auto parts stores.
 - The water and anti-freeze ratio must conform to manufacturer instructions.



CAUTION

- Use special washer fluid to prevent paint damage.

5. Prevent ice and snow from going under the fender.
 - Steering is difficult with ice or snow accumulating under the fenders. When driving in cold weather, stop from time to time and check for snow and ice under the fenders.

6. Have emergency tools or items available as prevention for difficult road conditions.
 - It is advisable to have snow chains, window scraper, bags of sand and salt, flashing signal, a shovel and connecting cables in the vehicle.

Driver Assistance



Adaptive Cruise Control (ACC)

- The Adaptive Cruise Control(ACC) system, an extension of traditional cruise control, uses a radar and a multi-purpose camera to detect the relative distance and speed of a vehicle ahead, so as to control vehicle speed accordingly for automatic cruise control. The system switches between regular cruise control and ACC depending on whether there is a vehicle ahead.
- Cruise speed and time interval from the vehicle ahead can be set by using the cruise buttons. Cruise control speed can be set within a 30 to 150 km/h (20 to 95 mph) range, or the time interval from the vehicle ahead can be set to cruise at speeds between 0 and 150 km/h (0 to 95 mph).

Status Description

- ACC not to be activated:
 - When vehicle power-on initialization has not been complete, the ACC system cannot be activated and the instrument cluster does not display corresponding icons
- ACC standby:
 - Once enabled, the system is on standby by default and can be

manually activated. If the vehicle does not meet activation conditions, it must be checked until such conditions are met. At this time,  (with a variable cruise speed value) is displayed on the instrument cluster.

- ACC activated:
 - The system is operational. It maintains the set speed or automatically adjusts the distance from the vehicle ahead for stable following. At this time,  (with a variable cruise speed value) is displayed on the instrument cluster.
- Over speed:
 - When the driver steps the accelerator pedal while ACC is active, the vehicle responds to the driver's acceleration action so that the ACC is temporarily deactivated until the accelerator pedal is released.
- ACC failure:
 - There has been a failure in the system. No operation can be performed, and the ACC failure indicator  lights up on the instrument cluster.

ACC Activation Conditions

- The EPB is released.
- The vehicle is in Drive.
- The vehicle does not slide backwards.
- The trunk, hood, and all doors are closed.
- The driver seat belt is fastened.
- The ESC system is started, but not activated yet.
- The vehicle speed is not greater than 150 km/h.

- Brake pedal is pressed at speed 0; or brake pedal is not pressed at speeds above 0.
- There is no vehicle network communication failure prompt on the instrument cluster.
- The AEB function is not activated.

How to Use

ACC activation/exit button

- Press button ① to activate or exit ACC. (The system is in standby when activation conditions are met). (By default, ACC activation by pressing button ① sets the current speed as the cruise speed. If the current speed is below 30 km/h, the cruise speed is set to 30 km/h.)

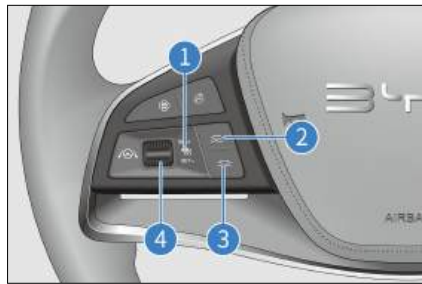

Resetting ACC

- When the ACC system is on standby within the same ignition cycle, the system memorizes the last speed setting. Push up the lever ④ to revert to the stored speed prior to exiting the cruise system.

Increasing/Decreasing target speed

- When ACC is active, set the vehicle to a speed within the 30-150 km/h range by moving the lever ④. Toggling the lever ④ up or down increases or decreases target speed by 5 km/h.

Exiting ACC

- While ACC is active, pressing button ① for a second time or pressing the brake pedal makes the ACC system go on standby.

Setting vehicle distance

- The driver must select a safe vehicle distance.
- The system adjusts vehicle speed to keep a suitable distance from the vehicle ahead on the same lane. Pressing buttons ② and ③ on the steering wheel adjusts vehicle distance to any of the four available levels. At each level, vehicle distance is in direct proportion to vehicle speed. The faster the speed, the longer the distance.

Increasing/Decreasing speed with ACC activated

- When ACC is activated, you can press the accelerator pedal to reach the set target cruise speed in advance. The system then enters over speed mode. At the target cruise speed, if you accelerate without performing any other operations, the vehicle accelerates and then returns to the target cruise speed after the accelerator pedal is released. If you press the brake pedal to slow down the vehicle speed continuously, ACC goes into standby mode. After the brake is released, ACC needs to be reactivated by pressing the button.

Follow-to-stop/start

- Controlled by ACC, the vehicle can stop when the vehicle ahead stops in normal driving conditions and resume driving automatically following the vehicle ahead if the stop is less than 30 seconds.
- If the vehicle stops for a time period within three minutes, press the accelerator pedal or push up lever ④ to reactivate ACC.

- If the vehicle stops for more than three minutes, the ACC system will enter standby mode, with EPB engaged.

System Limitations

- The radars are installed in the front of the vehicle. Blockage of its detection area by contaminants disturbs the intended function. In particular, if the sensor is covered by snow completely, the ACC system exits and informs of this on the instrument cluster. System function will recover after blockage is removed and the vehicle is restarted or runs on normal roads for a while.
- Front radar sensors may have a transient function failure from limited detection if the vehicle runs under special conditions, such as circular ramps or tunnels, for an extended period. The function can be recovered by restarting the vehicle or driving on normal roads for a while.
- Reaching or leaving a curve may delay or disturb target selection. In such cases, the ACC vehicle may not decelerate as expected or may decelerate late.
- On roads with sharp curves, such as winding roads, the vehicle ahead may be out of ACC sensor detection for several seconds due to sensor vision limitations, possibly causing the ACC vehicle to accelerate automatically.
- Traffic flow and weather conditions - such as rain and fog - must be heeded for setting vehicle distance on the ACC system. After the ACC system is properly set, the driver must be able to decelerate until the vehicle stops at any time.
- The ACC system may not be able to identify stationary or slow-moving objects, such as vehicles, the end of traffic, toll booths, bicycles, or pedestrians. This means a risk of

collision and requires the driver to beware of the surroundings.

- The ACC system cannot identify pedestrians or oncoming vehicles.
- The ACC system can only achieve limited braking instead of emergency braking.
- Metal objects, such as rail or metal plates used in road construction, may interfere with the radar, making it malfunction.

Precautions

- ACC is a comfort system rather than a safety system, obstacle detector or collision warning system. The driver must keep control of the vehicle at all times and be fully responsible for the vehicle.
- ACC assists instead of replacing the role of the driver. The driver should abide by traffic rules and keep vehicle control at all times, and is fully responsible for the vehicle.
- The ACC is suitable for highways and roads in good conditions, rather than complex urban or meandering roads.
- Vehicle control is transferred to the driver if the accelerator or brake pedal is pressed with ACC activated. As a result, the ACC system cannot keep a safe distance from the vehicle ahead.
- ACC may have no or slow responses to a vehicle ahead that brakes or stops suddenly, resulting in a risk of late braking. In such cases, there will be no take-over request.
- In some cases, such as when the vehicle ahead is going too slow, when lane change is too fast, or when the safe distance from the vehicle ahead is too short, there is no adequate time for the system to decrease the relative speed, so response has to come from

the driver. The system cannot give audible or visual warnings in every case.

- A short distance from an adjacent lane (or a vehicle on an adjacent lane that is too close to the ACC vehicle's lane) may trigger ACC to brake.
- Vehicles coming into the ACC vehicle's lane and within its radar detection range are identified as target vehicles and prompt a response accordingly, which may lead to hard or late braking.
- Detection may be affected or delayed in some environments. If the radar cross section of the target (a bicycle, four-wheeler, or pedestrian, for example) is too small, the system may not be able to establish its distance, resulting in either late or no response to those vehicles. In such cases, vehicle speed must be controlled by the driver. In addition, detection may also be affected or delayed by noise or electromagnetic interference.
- If the contact ratio of your vehicle with the vehicle ahead is too small, ACC will not be able to recognize the latter as a target, so the driver must keep control of the vehicle.
- When the vehicle stops as it follows a vehicle ahead, in rare cases, the system does not recognize the end of the vehicle ahead but the lower end of the target (for example, the rear axle of a truck with a high chassis or a vehicle bumper). In such cases, the system cannot ensure proper stop distance, so the driver must stay alert and be ready to brake.
- If ACC is activated with the vehicle stationary, the system identifies any stationary obstacle ahead and keeps the vehicle still to ensure a safe startup and prevent collision. However, this function cannot identify all the

obstacles, so the driver must be alert to the front obstacles or other traffic participants.

- ACC cannot be activated if special driving modes* such as tow/snow/mud/sand/terrain are enabled.
- Modifying the vehicle structure, such as lowering the chassis or changing the front license mounting plate, may affect the ACC system.
- Do not use the ACC system when visibility is poor, or when driving on slopes, winding roads, or wet roads (covered in ice/snow or flooded).
- Make sure to go to a BYD authorized dealer or service provider for professional calibration of the front millimeter-wave radar or multi-purpose camera in any of the following situations:
 - The front mmWave radar, front bumper, or front windshield has been removed.
 - Four wheels have been re-aligned due to wheel deviation.
 - The vehicle has experienced a collision.
 - ACC system performance has degraded or the instrument cluster has prompted a system error.



WARNING

- ACC serves as a driver assistance function only, so the driver is fully responsible for driving safety.
- Influence of weather, road conditions, and other factors may cause ACC to fail.
- Use ACC based on your needs, traffic, and road conditions.

Intelligent Cruise Control (ICC)*

- The intelligent cruise control (ICC) system integrates ACC and lane centering control (LCC). It helps control the vehicle both longitudinally and transversely at speeds between 0 km/h and 125 km/h to reduce the driving burden and provide a safe and comfortable driving environment.
- When the function is enabled, the driver must always hold the steering wheel and control the vehicle when necessary.
- Longitudinal assistance, driven by the ACC system, keeps the vehicle at a fixed speed or a fixed distance from the road user ahead.

Status Description



- ICC standby:
 - The ICC system is in standby by default and can be manually activated. If the vehicle does not meet activation conditions, the vehicle must be checked until such conditions are met. At this time,  is displayed on the instrument cluster.
- ICC activated:
 - The ICC system is operational. It maintains the set speed or automatically adjusts the distance from the vehicle ahead. At this time,  is displayed on the instrument cluster.
- ICC failure:
 - There has been a failure in the system. No operation can be performed, and the ICC fault

indicator  lights up on the instrument cluster.

ICC Activation Conditions

- The EPB has been released.
- The vehicle is in Drive.
- The vehicle does not slide backwards.
- The trunk, hood, and all doors are closed.
- Driver seat belt is fastened.
- The ESC system is on, but not activated yet.
- The vehicle speed is not greater than 125 km/h.
- Brake pedal is pressed at speed 0; or brake pedal is not pressed at speeds above 0.
- There is no vehicle network communication failure prompt on the instrument cluster.
- The AEB function is not activated.
- Two-way lane lines are clear and the vehicle is at the center of the lane.

How to Use

- Press  on the steering wheel to activate or exit ICC. (By default, when the function is activated, the current speed is set as the cruise speed. If the current speed is below 30 km/h, the cruise speed is set to 30 km/h.)
- For how to set the cruise speed and vehicle distance, see ACC function descriptions (in the previous chapter).
- You can also turn ICC on or off in infotainment touchscreen →  → **ADAS** → **Intelligent Driving**. (If already toggled on on the infotainment touchscreen, ICC can be toggled off

only when the vehicle is in Park.)
When the vehicle is just started up, ICC status before the last power-off is maintained.

Precautions

- ICC integrates ACC and LCC. Therefore, ACC function precautions must be followed during use (see the previous chapters for details).
- When ICC is turned on and activated at vehicle speeds between 0 km/h and 125 km/h:
 - If there is no lane lines ahead, transverse ICC control is suppressed and only ACC works. In that case, ICC working status indicator turns gray on the instrument cluster.
 - If lane lines ahead are clear and recognizable, transverse ICC control is activated automatically. In that case, ICC working status indicator shows activated status on the instrument cluster.
- The ICC system is a driving assistance system, not an automatic driving system. The driver should keep control of vehicle at all times, and their hands should not leave the steering wheel for a long time. Otherwise, the system will exit after prompting the driver to take over the control.
- The ICC system can be affected by weather conditions, lighting and clarity of lane lines. Performance degrades significantly in situations such as backlighting, sunset, snow covered roads, and severely damaged roads.
- Do not use the ICC system on winding roads with sharp turns, icy and slippery bends, or under weather conditions, such as dense fog, heavy rain and heavy snow, liable to hinder the sensing operation of front mmWave radars or the multi-purpose camera.

- Situations where ICC cannot be used include:
 - The sensor is blocked.
 - The vehicle is running under severe weather conditions.
 - Active safety function is triggered.
 - Vehicle speed exceeds the specified range.
- ICC cannot be activated if special driving modes* such as tow/snow/mud/sand/terrain are enabled.







WARNING

- ICC serves as a driver assistance function only, so the driver must be fully responsible for driving safety.
- Influence of weather, road conditions, and other factors may cause ICC to fail.
- Use ICC based on your needs, traffic, and road conditions.

Predictive Collision Warning (PCW)* & Automatic Emergency Braking (AEB)*

- Pedestrian Collision Warning (PCW) system and Automatic Emergency Braking(AEB) system detect vehicles and pedestrians ahead by using a radar and a multi-purpose camera. When detecting a risk of collision, the system gives audible and visual alarms to alert the driver and improves the potential braking pressure for better response timing. If detecting increased risk of collision, the system automatically applies braking pressure to assist in collision avoidance or impact reduction.

How to Use

- Enable or disable the PCW and AEB in infotainment touchscreen →  → **ADAS** → **Active Safety**. By default, the system is switched on when the vehicle is started.
- PCW gives alarms in forms of audio, messages, and intermittent braking.
- When PCW is activated,  or  flashes, depending on the level of emergency, and a prompt message is displayed on the instrument cluster.
- When AEB is triggered,  flashes together with a prompt message on the instrument cluster.
- In the event of malfunction,  is displayed.
- If you disable AEB manually by pressing buttons,  is displayed.

PCW Activation Conditions

- All the following conditions must be met:
 - This function has been turned on in Vehicle Settings.
 - If the vehicle is approaching a moving target, vehicle speed is between 30 km/h and 150 km/h. If it is approaching a stationary target, vehicle speed is between 30 km/h and 85 km/h.

AEB Activation Conditions

- All the following conditions must be met:
 - This function has been turned on in Vehicle Settings.
 - If the vehicle is approaching a moving target, vehicle speed is between 4 km/h and 150 km/h. If

it is approaching a stationary target, vehicle speed is between 4 km/h and 60 km/h.

- The EPB is released.
- The vehicle is in Drive.
- The vehicle does not slide backwards.
- The trunk, hood, and all doors are closed.
- Driver seat belt is fastened.
- The ESC system is on, but not activated yet.

System Limitations

- Detection may be affected or delayed in some environments. If the radar cross section of the target (a bicycle, three-wheelers, four-wheeler, or motorized bicycle, or motorcycle, for example) is too small, the system may not be able to establish its distance, resulting in either late or no response to those vehicles.
- In the following cases, the predictive emergency braking (PEB) system may be affected or give no response:
 - On rainy, snowy or foggy days, or exposure to direct sunlight or glaring lights, or significantly varying lighting conditions.
 - Dirty, hazy, damaged or blocked sensor.
 - Radar failure due to interference from other radar sources, such as strong radar reflection in multi-storey car park.
- In complex traffic, the system may be unable to properly respond to the following circumstances:

- Pedestrians or vehicles move too quickly into the sensor's detection range.
- Pedestrians are obscured by other objects.
- Pedestrian outlines are indistinguishable from the surroundings.
- Pedestrians are not detected, due to, for example, coverage by special clothing or other materials.
- The vehicle is on a sharp curve.

Precautions

- The PEB system cannot ensure zero collision. In complex traffic, the system cannot always clearly identify all the vehicles or pedestrians. It may trigger unnecessary warning or braking action for well covers, iron plates or road signs.
- Make sure to drive safely and observe surrounding traffic conditions. The AEB is not a substitute for normal braking operation in any event.
- Do not overly rely on the PEB system as this may result in severe injuries or deaths. The system is only an auxiliary safety tool. The driver must always keep a safe distance from vehicles ahead, control the speed, and be ready to brake or steer away when necessary. The driver must keep control of the vehicle at all times and be fully responsible for safe driving.
- The AEB system is activated only when it exceeds certain speeds. Careful driving is always required, because the system may not be triggered correctly.
- The AEB system cannot work normally when the ESC function is disabled or the fault light is on.

- If PCW gives an alarm, the driver must brake based on traffic conditions to decrease vehicle speed or steer away from obstacles.
- If the vehicle travels too close to the vehicle ahead for too long, a safety distance warning will be given. If the vehicle ahead brakes suddenly, collision may be unavoidable.
- The system will not trigger AEB when the driver is aware of an emergency warning but turns the steering wheel, accelerates, or brakes.
- The radar sensor may have a transient function failure from limited detection if the vehicle runs under special conditions, such as circular ramps or tunnels. The function may be recovered by restarting the vehicle or driving on normal roads for a while.
- Sometimes the surfaces of front mmWave radars or the multi-purpose camera are dirty or obscured by foreign objects. In that case, a message is displayed on the instrument cluster and both PCW and AEB are disabled. The functions will return after the sensor is cleaned.
- As the pedestrian protection function is limited by certain physical conditions, the driver must take timely and effective control of the vehicle under dangerous conditions.
- The system cannot completely protect pedestrians or avoid accidents and severe injuries on its own.
- Under certain complex conditions, such as on winding roads, the pedestrian protection function may trigger unnecessary warning or braking.
- System failure may trigger wrong warnings or braking. For example, the miscalibration of the mmWave radars or the camera.
- The brake pedal becomes harder if AEB is triggered. A large amount of hydraulic pressure will be required to push the caliper in a short time and there will be a sizzling noise.
- The PEB system is triggered only when the doors are closed and the seat belt is fastened. In the following circumstances, it will fail to work in the following cases:
 - Any door is not closed or it is opened when the vehicle is moving.
 - Any seat belt has not been fastened or it is unfastened while the vehicle is traveling.
 - The driver brakes hard.
 - The driver presses throttle hard.
 - The drivers frequently switches between the accelerator and brake pedals.
- System performance may be reduced in the following cases:
 - Strong front bumper impact from accidents or other causes.
 - Improperly inflated or worn out tires. Unqualified tires installed.
 - Snow chains installed.
 - Use of a small spare tire or tire repair kit.
- Make sure to go to a BYD authorized dealer or service provider for professional calibration of the front mmWave radar or multi-purpose camera in any of the following situations:
 - Removal of medium range radar or multi-purpose camera.
 - Toe-in or rear camber has been adjusted during wheel alignment.
 - The vehicle experienced a collision.

- ACC system performance has degraded or become abnormal.
- Do not attempt to test the PEB system on your own using objects such as carton, iron plate, dummy, etc. The system may not work properly and thus result in accidents.



WARNING

- PCW and AEB serve as driver assistance functions only, so the driver is fully responsible for driving safety.
- Influence of weather, road conditions, and other factors may cause PCW and AEB to fail.
- Use PCW and AEB based on your needs, traffic, and road conditions.

Front cross traffic alert (FCTA)/front cross traffic braking (FCTB) system detects vehicles crossing the driveway at the front through front mmWave radars on both sides of the front bumper to alert the driver and engage the brake if necessary. At low vehicle speeds, when the system detects a risk of collision with a vehicle crossing the driveway at the front, it provides the driver with visual and audible alerts; in the event of an impending collision, the vehicle brakes automatically.

How to Use

- Enable or disable the FCTA and FCTB in infotainment touchscreen →  → **ADAS** → **Active Safety**.
- When the function is activated, ambient light for instrument cluster, ambient light on the left of the front row, and rearview indicator flash.

- When FCTB is activated,  flashes together with a prompt message on the instrument cluster.
- In the event of FCTA/FCTB malfunction,  is displayed.

Precautions

- While the FCTA/FCTB system provides assistance in front monitoring, it cannot replace the driver's observation and judgment. The driver must keep control of vehicle at all times and drive properly and is fully responsible for the vehicle.
- When a target vehicle is approaching from the side at a high speed, the FCTA/FCTB system may not be able to provide adequate warning.
- The driver must ensure the normal operation of the system, keeping mmWave radars on both side of the bumper in good condition. For example, dirt, snow, or other obstructions need to be cleared right away.
- Detection may be affected or delayed in some environments. If the radar cross section of the target vehicle is too small (a bicycle, electric moped, or pedestrian, for example), the system may fail to identify targets and raise false alarms. In addition, detection may also be affected or delayed by noise or electromagnetic interference.
- Under some circumstances, it is difficult for the system to assist the driver, and detection may be affected or delayed. Possible circumstances include, but are not limited to:
 - The vehicle coming from the side changes the lane suddenly.
 - The target vehicle is obscured.

- The radar cross section of the target vehicle (for example, a bicycle or electric moped) is too small.
- Severe weather, such as rain or snow.
- Radar coming off, loosely installed, or blocked;
- The vehicle encounters complex metal guardrails or similar road conditions.
- The system does not work when:
 - Targets are outside the mmWave radar's detection range.
 - FCTA or FCTB is switched off.
 - The vehicle is not in Drive.
 - Four doors are open.
 - System initialization has not been complete yet.
 - Front corner radar fails.
 - The vehicle is running at a speed above 9 km/h or is stationary.
 - Vehicles coming from the front left or right side are detected too late at sharp turns, slopes, or other settings.
 - Target vehicle speed is outside the 7 km/h~63 km/h range.
 - The vehicle starts up quickly after stopping or has been started for three seconds.
- Influence of vibration or collision on BSD radar sensor calibration can degrade system performance. If this is detected, contact a BYD authorized dealer or service provider.

WARNING

- FCTA/FCTB serves as a driver assistance function only, so the driver must be fully responsible for driving safety.





WARNING

- Influence of weather, road conditions, and other factors may cause FCTA/FCTB to fail or lead to late braking.
- Use FCTA/FCTB based on your needs, traffic, and road conditions.

Traffic Sign Recognition (TSR)*

The traffic sign recognition (TSR) system identifies speed limit signs through the multi-purpose camera, displays such signs on the current road on the instrument cluster, and sends alarm messages to the driver when vehicle speed exceeds the detected speed limit.

How to Use

- Enable or disable TSR in infotainment touchscreen →  → **ADAS** → **Driving Assist**. The system defaults to settings just before the last power-off when the vehicle starts.
- The speeding alarm threshold can be changed by adjusting the sensitivity of the speed limit alarm.
- When TSR is enabled and identifies the current traffic sign,  (with value in accordance with the sign) is displayed on the instrument cluster.
- When TSR is enabled but unable to identify traffic signs,  is displayed on the instrument cluster.
- If the TSR system malfunctions,  is displayed.

- If you disable TSR manually by pressing buttons,  is displayed.

Precautions

- The speed limit icon disappears from the instrument cluster within a certain distance after system recognition. The driver must control speed within range.
- The traffic sign recognition system can identify speed limit signs only, and will not control speed. The control over the vehicle always vests in the driver. Please drive properly.
- When there are several speed limit signs on side-by-side lanes, the system recognizes the limit sign of current lane to display the speed limit alert icon. The driver must remain in the correct lane.
- Weight limit signs not in standard size as per national regulations may mistakenly be identified as speed limit signs.
- If a speed limit sign is unclear or distorted, inclined, reflective, partly blocked or covered, the camera may be unable to recognize the sign completely or clearly.
- TSR performance depends on weather conditions, lighting, and sign visibility. The system may fail to or incorrectly identify the sign at night or sunset, in rainy, foggy, hazy, snowy or dusty environment, when light is coming from the back of the vehicle, or when there is a sudden change in lighting.
- In case there is a collision or the camera sensor has been reassembled, it is recommended to go to a BYD authorized dealer or service provider for sensor calibration so as to avoid affecting system performance.

WARNING

- TSR serves as a driver assistance function only, so the driver must be fully responsible for driving safety.
- Influence of weather, road conditions, and other factors may cause TSR to fail or lead to late alarms.
- Use TSR based on your needs, traffic, and road conditions.
- The Intelligent Speed Limit Control (ISLC) system integrates ACC and TSR. With the system enabled, if the vehicle travels faster than the detected speed limit, a confirmation prompt is displayed asking whether to set cruise speed to that limit. After the driver confirms, the system will automatically set cruise speed to the limit to prevent speeding.
- This function is accessible at the 30-150 km/h range of speed.

How to Use

- Enable or disable ISLC in infotainment touchscreen →  → **ADAS** → **Driving Assist** → **TSR** → **ISLC**.
- When the TSR system is disabled, the ISLC switch is grayed out and unusable. ISLC is turned off at this time. The ISLC switch will be usable after the TSR system is enabled again.
- ISLC can be activated provided that ACC is active.

Precautions

- ISLC integrates ACC and TSR. Therefore, ACC and TSR function precautions must be followed during

use (see the previous chapters for details).

- The intelligent cruise control system is a driving assistance system, so the driver should keep control of vehicle at all times.
- ISLC performance depends on weather conditions, lighting, and traffic sign visibility. The system may fail to or incorrectly identify the sign at night or sunset, in rainy, foggy, hazy, snowy or dusty environment, when light is coming from the back of the vehicle, or when there is a sudden change in lighting.



WARNING

- ISLC only serves as a driver assistance function, so the driver must be fully responsible for driving safety.
- Influence of weather, road conditions, and other factors may cause ISLC to fail or lead to late alarms.
- Use ISLC based on your needs, traffic, and road conditions.

High Beam Assist (HMA)*

High beam assist (HMA) assesses current driving conditions by using multi-purpose camera sensors and automatically activates or deactivates the high beam accordingly, when vehicle speed exceeds 25 km/h.

Status Description

- HMA standby:
 - When the function is enabled but not activated yet,  is displayed on the instrument cluster.
- HMA activated:
 - With the function enabled, when the light switch is on "Auto", the light meets conditions, and vehicle speed exceeds 35 km/h,  is displayed on the instrument cluster.
 - HMA failure:
 - HMA has failed, and  is displayed.

How to Use

- Enable or disable HMA in infotainment touchscreen →  → **ADAS** → **Driving Assist**. When the vehicle is started, the system defaults to previous settings.
- With the function enabled, when you set the light switch to the auto lights position, the light meets conditions and vehicle speed exceeds 35 km/h, the system automatically switches between low and high beams based on the current driving environment.

Precautions

- The HMA system is an auxiliary light control function. While it is recommended to use the system at high vehicle speeds, the system cannot completely replace the driver's judgment. The driver must observe road regulations and actively switch between high and low beams according to road condition changes at all times.
- HMA system exits when you turn fog lights on, set wipers to fast mode, are backing up, or set the light switch to a position other than auto lights, or when the environment has too much lighting.
- Even when HMA is working, the driver must respond to possible situations where the HMA is triggered in error or fails to work due to unavoidable environmental factors and conditions. Typical situations are:

- The driver's stick operation to switch to the high beam is prioritized.
- The weather, such as fog, rain or snow, is extremely terrible for driving.
- There are traffic participants with poor lighting (such as pedestrians and bicycles), railways or waterways nearby, or wild animals on the roads.
- There are strongly reflective objects around, such as traffic signs on highways and water reflection on the road surface.
- The front windshield is dirty, covered in mist, or blocked by stickers or decorations.
- In case there is a collision or the sensor has been reassembled, it is recommended to go to a BYD authorized dealer or service provider for sensor calibration so as to avoid affecting system performance.

WARNING

- HMA serves as a driver assistance function only, so the driver must be fully responsible for driving safety.
- Influence of weather, road conditions, and other factors may cause HMA to fail.
- Use HMA based on your needs, traffic, and road conditions.

Lane Departure Assist (LDA)*

Lane Departure Warning(LDW)*



- The lane departure warning (LDW) system detects the lane lines ahead through a multi-purpose camera. When the vehicle speed is 60–150 km/h



and the driver unintentionally drifts out of the lane, the LDW system warns the driver by steering wheel vibration, audible alarm, and an instrument cluster prompt.

Lane Departure Prevention(LDP)*

- The lane departure prevention (LDP) system identifies lane lines ahead through a multi-purpose camera. If the driver unknowingly departs from the lane at a vehicle speed between 60 km/h and 150 km/h such that the vehicle is about to roll over lane lines, the system, when activated, slightly turns the steering wheel by providing reverse torque through the electronic power steering (EPS) system to prevent lane departure.
- If LDP system is activated, it gives alarms to the driver (in the form of audible alarm, visual alarm, and steering wheel vibration) and the alarms continue until this activation ends. If the system is activated twice or more within a continued 180-second cycle and no turn input comes from the driver during this activation period, the system alarms when it is activated for the second time or any further intervention is performed. For the third intervention (and any further ones), alarms are extended by at least 15 seconds.

How to Use

- To enable or disable LDA, go to infotainment touchscreen →  → **ADAS** → **Driving Assist** → **Lane Support System (LSS)**.
- Options of LDW alarm forms include audio alarm only, or steering wheel vibration only, and both.
- When LDW or LDP is enabled,  is displayed on the instrument cluster.

- When activated, LDW gives alarms (in the form of audible alarm, visual alarm, and steering wheel vibration). On the instrument cluster, virtual lane lines on the side where the vehicle rolls over lane lines turn red.
- When activated, LDP gives alarms (in the form of audible alarm, visual alarm, and steering wheel vibration). On the instrument cluster,  flashes twice, virtual lane lines on the side where the vehicle rolls over lane lines turn blue.
- In the event of malfunction,  is displayed.
- LDW may be suppressed if the vehicle travels over lane lines or if lane lines are unclear, too thin, worn, blurred, or covered by dirt/snow.
- LDW may be suppressed if the lane is too wide or too narrow, if the number of lanes increases or decreases, if lane markings change suddenly on ramps or exits, or in situations of complex line arrangements.
- LDW may be suppressed on slopes or winding roads when the vehicle travels too close to the vehicle ahead or when the vehicle ahead obscures lane lines.
- LDW may be suppressed when the vehicle jolts, accelerates or decelerates too quickly, or takes a sharp turn.

System Limitations

- The LSS may detect incorrect or no lane lines in complex traffic. The following situations may lead to failure or performance degradation of the system:
 - Poor visibility on snowy, rainy, or foggy days.
 - Dirty or fogged windshield, or blocked multi-purpose camera
 - Glaring from direct sunlight, reflection in puddles, or oncoming vehicles.
 - Sudden changes in light, such as when the vehicle is entering or exiting a tunnel.
 - Lane lines obscured by tree shadows on roads in direct sunlight on sunny days.
 - Unidentifiable road boundary with grass, soil, or curb.
- The system operation may be affected if the windshield within the camera visual field is cracked, if the glass is dyed or inadequately coated; or if any reflecting object is placed on the dashboard or any other object interferes with camera sight.
- For safety reasons, do not test LDW function on your own. The function will be interrupted if any object blocks the camera or if it is exposed to strong lights. The function will be temporarily exit if the view is temporarily covered and disturbed by strong light and will recover once conditions return to normal. If it does not, it is recommended to contact a BYD authorized dealer or service provider.
- Disabling the LDW is recommended under any of the following circumstances:
 - Driving in a sporty style
 - Severe weather conditions
 - On uneven roads

Precautions

- LDW will be suppressed if a turn signal is used and the vehicle changes lane as indicated by the turn signal.

- Situations where lane lines may not be identified include, but are not limited to:
 - Unclear lane lines
 - Incomplete lane lines.
- Situations that may result in detection failure of the camera or late activation of the function include but are not limited to:
 - Camera coming off, loosely installed, or blocked;
 - Rain, snow, smog, and other extreme weathers;
 - Partially or completely blocked camera lens.

WARNING







- LDA serves as a driver assistance function only, so the driver must be fully responsible for driving safety.
- Influence of weather, road conditions, and other factors may cause LDA to fail.
- Use LDA based on your needs, traffic, and road conditions.

Emergency Steering Assist (ESA)*

The emergency steering assist (ESA) system identifies lane lines ahead through a multi-purpose camera and identifies vehicles approaching from behind on the adjacent lanes through rear corner radars. It comes to work within the 60-150 km/h vehicle speed range when the vehicle drifts out of solid lane lines, begins to change the lane, or has a risk of colliding with oncoming vehicles or vehicles that are passing it on adjacent lanes. The system activates EPS

system to provide reverse torque, keeping the vehicle in the current lane.

How to Use

- To enable or disable ESA, go to infotainment touchscreen →  → **ADAS** → **Driving Assist** → **Lane Assist System**.
- When ESA is active,   flashes on the instrument cluster.
- In the event of ESA malfunction,   is displayed.
- If you disable ESA manually by pressing buttons,  is displayed.

Precautions

- Situations where lane lines may not be identified include, but are not limited to:
 - Pedestrians, animals, and specialty or specially-shaped vehicles
 - Unclear or incomplete lane lines
- Situations that may result in detection failure of the camera or late alarm include but are not limited to:
 - Camera coming off, loosely installed, or blocked;
 - The vehicle is running under extreme weather, such as rain, snow, or smog.
 - Partially or completely blocked camera lens.
- Situations that may result in detection failure of the radar or late alarm include but are not limited to:
 - Radar coming off, loosely installed, or blocked;
 - Rain, snow, smog, and other extreme weathers;

- The vehicle encounters certain metal guardrails or similar road conditions.



WARNING

- ESA only serves as a driving assistance function, so the driver must be fully responsible for driving safety.
- Influence of weather, road conditions, and other factors may cause ESA to fail.
- Use ESA based on your needs, traffic, and road conditions.

Blind Spot Assist (BSA)*

The blind spot assist (BSA) system includes the following functions: blind spot detection (BSD), rear cross traffic alert (RCTA), rear collision warning (RCW), and door open warning (DOW). It detects environment behind the vehicle through radars installed on both sides of the rear bumper so as to remind the driver of safe driving.

BSD*

- When speed is above 15 km/h and the sensor detects a vehicle within the blind spot of a side mirror or approaching quickly on the adjacent lane, its indicator lights up. If the turn signal for the same side is turned on at this moment, the alarm indicator on the side mirror flashes to alert the driver of a risky lane change.

RCTA*

- When the vehicle is reversing, the RCTA system detects the vehicles traveling in the blind spot at the back through radar. If the system determines that a vehicle approaching from behind poses a risk of collision, warning lights on side mirrors, instrument cluster ambient lights, and front ambient

lights flash to alert the driver, reducing the possibility of collision.

RCW*

- At vehicle speeds above 5 km/h, if radar sensors detect a risk of collision with a vehicle approaching quickly from behind on the current lane, instrument cluster ambient lights and front ambient lights flash to alert the driver and the hazard warning light turns on to warn the driver of the approaching vehicle of collision risk.



DOW*

- DOW is realized with rear corner radars installed on both sides of the rear bumper. When the vehicle is stationary with doors unlocked, the system keeps indicators on side mirrors solid on to warn the driver if moving objects, such as bicycles or automobiles, approach from behind on an adjacent lane. At the same time, image and prompt message are displayed on the instrument cluster and front- and rear-row ambient lights are solid on. If the driver attempts to open the door at this time, indicators on side mirrors and front- and rear-row ambient lights begin to flash.

How to Use

- Enable or disable BSD, RCTA, RCW, or DOW in infotainment touchscreen →  → **ADAS** → **Active Safety** → **Blind Spot Assist**. When the vehicle is started, the system defaults to previous settings.
- When the blind spot assist system is disabled, no relevant indicators are displayed on the instrument cluster.
- When the blind spot assist system is standing by, if vehicle conditions, such as speed or gear status, do not meet the requirements of any function,

 is displayed on the instrument cluster and blind spot assist will not be activated.

- If the blind spot assist system malfunctions,  is displayed.
- When the blind spot assist system is active,  is displayed on the instrument cluster, meaning that the function has been activated and can trigger alarms at any time.

Precautions

- While the BSD system provides assistance in monitoring blind spots of rearview mirrors, it cannot replace the driver's observation and judgment. The driver must keep control of vehicle at all times and drive properly and is fully responsible for the vehicle.
 - The BSD system may be unable to provide adequate warning on target vehicles approaching from behind at a high speed.
 - The driver should ensure the normal operation of the BSD system, keeping the BSD radar sensors in good condition. For example, if they are covered in dirt, snow or other obstructions, they need to be cleared right away
 - If unrelated targets at the rear side or in the rear (such as large roadside barriers used during road repair, large billboards by the road, reflectors in tunnels, or other objects with a large reflection cross-sectional area) are wrongly selected as target vehicles, the BSD system will give an alert.
- Under some circumstances, it is difficult for the system to assist the driver, and detection may be affected or delayed. Possible circumstances include, but are not limited to:
 - The vehicle coming from behind changes the lane suddenly.
 - Vehicles coming from behind are detected too late at sharp turns, slopes, or other settings.
 - The target vehicle is obscured.
 - The vehicle is on a curve which is too sharp, or is entering or exiting a curve.
 - Severe weather, such as rain or snow.
 - Radar coming off, loosely installed, or blocked;
 - The vehicle encounters certain metal guardrails or similar road conditions.
 - Targets that may not be responded include, but are not limited to, pedestrians and animals.
 - The environment contains electromagnetic interference or other influences.
 - Influence of vibration or collision on BSD radar sensor calibration can degrade system performance. If this is detected, contact a BYD authorized dealer or service provider.

WARNING

- Blind spot assist serves as a driver assistance function only, so the driver must be fully responsible for driving safety.
- Influence of weather, road conditions, and other factors may cause blind spot assist to fail.

System Limitations

WARNING

- Use blind spot assist based on your needs, traffic, and road conditions.

Head-up Display (HUD)*

The head-up display (HUD) function projects important information, including vehicle speed, speed limit, ACC, lane departure, and BSD into the driver's field of view on the front windshield. It improves driving safety by preventing the driver from frequently changing the focus of their eyes.





- You can access the setting screen in infotainment touchscreen →  → **Vehicle Settings** → **HUD**.
 - HUD switch: By factory default, the switch is toggled on and a HUD image is displayed. When the switch is toggled off, no HUD image is displayed. The system defaults to the previous settings when the vehicle restarts.
 - Height Adjusting: adjust the brightness of HUD virtual image in between -10 and 10. A total of 21 values are available, and the default value is 0.
 - Brightness Adjusting: Used to adjust the height of HUD virtual image in between 1 and 11. A total of 11 values are available, and the default value is 6.

- Whirling Adjusting: Used to adjust the angle of HUD virtual image to -2°, -1.6°, -1.2°, -0.8°, -0.4°, 0°, 0.4°, 0.8°, 1.2°, 1.6°, or 2°. The default value is 0°.
- Mode Setting: select **Classic** (default setting) or **Snow** mode according to the service environment of the vehicle.
- Settings optional for display: Two types of settings are optional for display and are both turned on by default: safe driving assistance and navigation. Tap the button to select the setting for HUD display. Tap the button again to deselect and close the item.

Tire Pressure Monitoring System (TPMS)

Direct Tire Pressure Monitoring

- The Tire Pressure Monitoring System (TPMS) is an auxiliary system that monitors tire pressure in real time to improve vehicle safety and comfort and reduce tire wear and energy consumption due to insufficient tire pressure.
- You can access the instrument cluster menu by pressing the  button on the steering wheel, navigate to the driving information bar by pressing the  and  buttons, and then select the tire pressure display screen using the scroll button.

Tire pressure system alarm

- When the pressure of any tire is lower than 75% of the standard tire pressure and the system is running, the tire pressure fault warning light lights up and the tire pressure value turns yellow. In that case, it is recommended to stop the vehicle to check for slow

air leakage and inflate the tire to the correct pressure value.

- When the temperature of any tire is above 85°C for three consecutive minutes, the tire pressure system gives a high temperature alarm, and the temperature value of the corresponding tire turns yellow. You are then recommended to stop the vehicle and wait for the tire temperature to decrease before further driving.
- When the system is running, if a fault occurs, the tire pressure fault warning light is solid on after flashing, and the message "No Signal" or "Please check TPMS" is displayed on the instrument cluster. In that case, check the tire pressure monitoring module, and check for any surrounding electromagnetic source nearby. If the alarm persists for a long time, please contact a BYD authorized dealer or service provider.

 **WARNING**

- The system does not stop vehicle traveling in the event of abnormal tire pressure. Therefore, each time before driving, make sure the tire pressure meets the requirements specified by the manufacturer. If not, do not drive, otherwise vehicle damage or personal injury may occur.
- If pressure is found to be abnormal while driving, check the tire pressure immediately. If the low pressure warning light comes on, avoid sharp turns or emergency braking, reduce vehicle speed, and pull it over to the curb and stop as soon as possible. Driving with low tire pressure can cause permanent damage to tires and increase

 **WARNING**

the likelihood of tire scrapping. Serious tire damage can lead to traffic accidents, resulting in serious injuries or deaths.

 **CAUTION**

- The running time of the tire pressure monitoring module is related to the daily travel distance and other factors.
- The monitoring module regularly transmits tire pressure and other information to the display. Therefore, if the tire pressure drops suddenly or there is a flat tire, the monitoring module will not transmit data to the display until the next monitoring. In this case, the vehicle may be out of control. If there is a flat tire and monitoring fails to inform, or if you feel that there are some tire problems, stop driving immediately instead of waiting for the display to signal an alarm.
- Incorrectly installed monitoring module affects the air tightness of the tire. It is recommended that the installation and replacement of the pressure monitoring module be carried out by professional technicians of a BYD authorized dealer or service provider in accordance with the requirements of the installation manual.
- Since tire pressure varies with regional temperatures, inflate or deflate the tires according to the values displayed on the instrument cluster and the standard tire pressure values.

CAUTION

- The tire pressure monitoring system may be disturbed by non-BYD approved electrical accessories on the vehicle. This is not a tire pressure system failure.
- The tire pressure system needs to be matched again after replacement of wheel rims or spare tires* or tire rotations. Please go to a BYD authorized dealer or service provider to re-match the tire pressure.

Acoustic Vehicle Alerting System (AVAS)

System Function

The Acoustic Vehicle Alert System (AVAS) refers to the broadcast to pedestrians near the vehicle when it is traveling at low speed.

- When driving forward:
 - The broadcast volume increases with increment of vehicle velocity that is at $0 \text{ km/h} < V \leq 20 \text{ km/h}$.
 - The broadcast volume decreases with increment of vehicle velocity that is at $20 \text{ km/h} < V \leq 30 \text{ km/h}$.
 - The broadcast sound stops automatically when vehicle velocity is greater than 30 km/h .

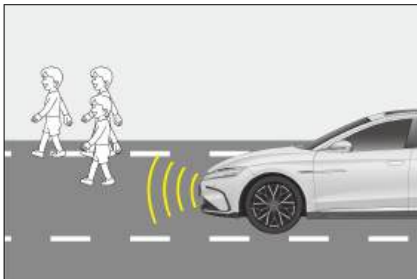

- The vehicle makes a continuous and balanced prompt sound when moving in reverse.

Disabling/Enabling the System

To turn on or off the engine sound simulator, slide down the top status bar on the infotainment touchscreen to display the shortcut screen. The system is enabled by factory default. AVAS has two sound sources: standard and brand. To choose a sound source, go to infotainment touchscreen →  → **Vehicle Settings** → **Notification**.



CAUTION

- Due to different vehicle configurations and the functions activated, the displayed icons on the shortcut menu vary. Specific applications are subject to actual vehicle configurations and the functions activated.

WARNING

- The AVAS pause switch can only be used if there are no other road users within a short distance, and no audio prompt is needed considering the surroundings (for example, in a traffic jam or on the motorway). As long as pedestrians may appear around the vehicle, the AVAS needs to be turned on.

WARNING

- If the vehicle is running at low speed with AVAS turned off, it is unable to alert pedestrians to the vehicle approaching, decreasing vehicle safety.
- If the AVAS prompt sound cannot be heard when driving at a low speed, stop the vehicle in a relatively safe and quiet place, open a window, then drive in R gear with a speed of 20 km/h and check whether you can hear an audible prompt from the front of the vehicle. If it is confirmed that there is no sound, contact a BYD authorized dealer or service provider to deal with it.

Panoramic View

To enable the panoramic view, tap **Vehicle View** on the infotainment system homepage, and press the button on the steering wheel or shift into Reverse.



- On the bottom of the infotainment touchscreen, tap the icon for front, rear, right, or left view. View of the selected area is displayed in the image section on the left.



- In the single front and rear views, double-tap the image section to switch to a 180° perspective displayed in full screen.
- Tap the radar icon  in the panoramic view to enable the radar display, and tap it again to disable. When the radar display is enabled, an obstacle warning is displayed as it is approached.
- Slowly tap the body image on the left to switch between visible and invisible body.
- After the vehicle starts, the image before last power-off is displayed on the transparent panoramic view screen. Foreign bodies shown may be inconsistent with the actual ones in the underbody and surrounding blind areas. The underbody image update will begin only after the vehicle has started to run and will be complete when the vehicle has been driven beyond its length.



WARNING

- This system uses wide-angle fisheye cameras, so the object

WARNING

on the display screen may appear somewhat deformed in comparison with the actual object.

- The panoramic view system is only to be used for parking/driving assistance. It is not safe to rely solely on this system to park or drive the vehicle, because there are some blind spots in front of and behind the vehicle. The surroundings of the car should be observed in other ways during the parking/driving process, so as to avoid accidents.
- When the side mirrors are not extended in place, do not use the panoramic view system; and when the panoramic view system is used for parking/driving, ensure that all the car doors are closed.
- The distance to an object displayed on the panoramic view screen may be different from the distance perceived subjectively, especially when the object is closer to the vehicle. Assess the distance in various ways.
- Cameras are installed above the front bumper, the lower parts of the side mirrors, and the rear license plate. Make sure the cameras are unobstructed.
- To prevent affecting camera performance, avoid spraying directly on the cameras when washing the vehicle body with high-pressure water. Wipe any water or dust off the camera in time.
- Protect the cameras from any impact to prevent damage or malfunction.

WARNING

- After the vehicle is powered on, if you press the panoramic view start button or shift into reverse while the infotainment system is not fully activated, the output on the panoramic view screen will be delayed or the screen will flash. This is a normal part of the camera power-on process.
- When the vehicle runs at a low speed, the transparent panoramic view function is affected by speed fluctuation or multiple stops, so there will be misalignment between the images below the vehicle and that outside the vehicle.

Parking Assistance

Parking Radar Switch

Turn the parking radar system on or off with the parking radar switch or in infotainment touchscreen →  → **ADAS** → **Parking Assistance**.



- When the ignition is on and EPB is released, the parking assist system is enabled automatically.
- When enabled, the system raises an alarm if obstacles are found surrounding the vehicle; when disabled, it does not.

Sensor Type

- When the sensor detects an obstacle, an image is displayed on the infotainment touchscreen* according to the location of the obstacle and its distance from the vehicle.
- When the driver conducts parallel parking or reverse parking, the sensor measures the distance between the vehicle and the obstacle and communicates this information through the infotainment touchscreen and the speaker. Be aware of the surroundings when using this system.

- ① Front right sensor
- ②③ Front center sensors
- ④ Front left sensor
- ⑤ Rear left sensor
- ⑥⑦ Rear center sensors
- ⑧ Rear right sensor

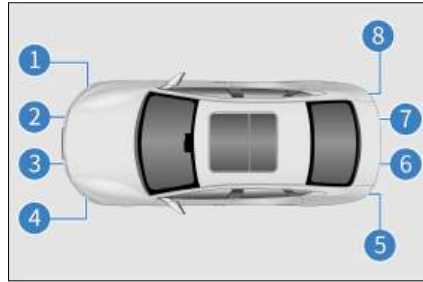

⑧ Rear right sensor





Distance Display and Speaker

When the sensor detects an obstacle, the location of the obstacle and its approximate distance from the vehicle is displayed on the infotainment touchscreen, and the speaker beeps.

Working example of center sensors

Approximate Distance (mm)	Touchscreen Display Example	Alarm Sound
About 700 to 1,200		Slow
About 300 to 700		Fast
About 0 to 300		Continuous

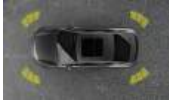
Working example of corner sensors

Approximate Distance (mm)	Touchscreen Display Example	Alarm Sound
About 300 to 600		Fast
About 0 to 300		Continuous

Working Sensors and Detection Range

All sensors are activated upon reversing.

The illustration shows the sensors' detection range. Sensors have a range limitation, so drivers must check the surroundings before slowly reversing the vehicle.

- ① About 1,200 mm
- ② About 600 mm

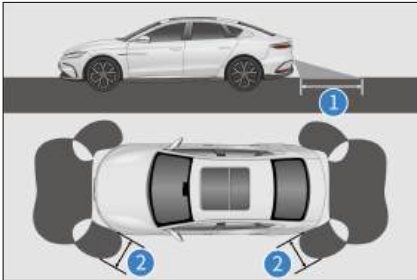

! REMINDER

- The parking assist system is only for assistance, and is not a substitute for personal judgment. Be sure to operate the vehicle based on your observations.
- Sensors will not work properly if accessories or other objects are placed within their detection range.

! REMINDER

- In some cases, the system cannot operate properly and will fail to detect certain objects as the vehicle approaches them. Therefore, be sure to observe the vehicle's surroundings at all times. Do not rely solely upon the system.

Sensor Detection Information

- Certain vehicle conditions and surroundings may affect the sensors' ability to accurately detect obstacles. Detection accuracy may be affected if:
 - There is dirt, water or fog on the sensor.
 - There is snow or frost on the sensor.
 - The sensor is masked in any way.
 - The vehicle leans significantly to one side or is excessively overloaded.
 - The vehicle is moving on particularly bumpy roads, slopes, gravel or grass.
 - The sensor has been repainted.
- The vicinity is noisy due to honking of vehicles, motorcycle engines, air brakes of large vehicles, or other noises that produce ultrasonic waves.

- There's another vehicle with parking assist system nearby.
- The vehicle is fitted with a tow eye.
- The bumper or the sensor was hit hard.
- The vehicle is approaching a high or zigzag curb.
- The vehicle is driven in the hot sun or severely cold weather.
- The vehicle is fitted with non-original, lower suspension.
- Except as described above, sensors may not be able to correctly determine the actual distance of some objects due to their shapes.
- The shape and material of obstacles may prevent sensors from detecting them, especially the following:
 - Electric wires, fences, and ropes
 - Cotton, snow, and other materials that absorb radio waves
 - Any object with sharp edges and corners
 - Low obstacles
 - High obstacles facing outwards towards the vehicle
 - Any object under the bumper
 - Any object close to the vehicle.
 - Persons near the vehicle (depending on the type of clothing).
- If an image is displayed on the infotainment touchscreen* or there is a beep, it may be that the sensor detects an obstacle or is interfered. If the issue persists, go to a BYD authorized dealer or service provider for inspection.



CAUTION

- To prevent sensor malfunction, do not rinse or apply steam to the sensor area.

Driving Safety Systems

For better driving safety, the following driving safety systems works automatically based on driving conditions. However, these systems only provide assistance, and excessive reliance on them is not recommended.

Intelligent Power Braking System

The intelligent power braking system is an advanced decoupled electro-hydraulic brake system, incorporating vacuum booster, electronic vacuum pump, Antilock Braking System (ABS)/Electronic Stability Controller(ESC) system and other features. The system assists vehicle braking according to the driver's demands. It offers advanced control functions such as ABS, electronic brake force distribution (EBD), traction control system (TCS), vehicle dynamic control (VDC), comfort parking (CST), hill-start hold control (HHC), hydraulic brake assist (HBA), and controlled deceleration for parking brake (CDP) to improve vehicle stability and comfort, and the recovery efficiency of brake energy.

Vehicle Dynamics Control(VDC)

When the vehicle turns suddenly while running, the VDC system judges the driver's intention based on such information as steering wheel's angle and vehicle speed, and continuously compares it with the actual condition. If the vehicle deviates from the normal lane, the VDC corrects the situation by engaging brakes to the corresponding wheels to help the driver control skidding and maintain directional stability.

Traction Control System(TCS)

TCS prevents the drive wheels from skidding during acceleration by reducing the motor power, and, when necessary, applies braking forces to prevent drive wheels from spinning. It makes it easy for the vehicle to start, accelerate, and climb under adverse driving conditions.

WARNING

- TCS may not work effectively in the following situations:
 - On slippery roads, even if TCS is working properly, it may not be able to control the direction and meet power requirements.
 - Do not drive in conditions where the vehicle may lose its stability and power.

Hill Hold Control(HHC)

After you release the brake pedal, HHC maintains the brake pressure you imposed for 1.5 seconds to prevent backward sliding of the vehicle.

Hydraulic Brake Assit(HBA)



When you press the brake pedal quickly, HBA detects that the vehicle is in emergency condition. It quickly increases the brake pressure to the maximum so that ABS can intervene more quickly and shorten the braking distance effectively.

Controller Deceleration Parking(CDP)

When you engage the EPB, the CDP function* starts working so that the vehicle brakes at a constant deceleration (0.4 g if EPB is engaged but the brake pedal is not pressed, and 0.8 g if EPB is engaged and the brake pedal is pressed) until the vehicle stops. The function stops working when the EPB is released.

ESC operation instructions

Intelligent power braking system has the following new functions compared with the original ESC system:

- Brake assist mode
 - The brake assist mode is used to adjust the brake pedal feel. The relation curve between the brake pedal depth and the vehicle deceleration varies across different modes for the driver to choose their preferred pedal feel.
 - Adjust the brake pedal feel in infotainment touchscreen →  → **Vehicle Settings** → **Intelligent Chassis** → **Brake Assist Mode**.
- Comfort parking
 - Comfort parking function: When the vehicle decelerates to stop in a non-emergency situation, the intelligent power braking system reduces the stop-instant suspension pitch and impact by controlling the brake pressure of the four brakes, providing a smooth stop feeling for the driver.
 - Enable or disable this function in infotainment touchscreen →  → **Vehicle Settings** → **Intelligent Chassis** → **Comfort Parking**.
 - After the function is triggered, the braking distance may increase by 2-5 cm. Increase the distance from the vehicle or obstacle ahead accordingly before stopping your vehicle.
- Brake disc wiping
 - Brake disc wiping function: When the wiper switch is on or the rain sensor detects rain, the intelligent power braking system applies a small brake pressure to all four brakes so that pads come into contact with discs to remove the water film from the discs. This shortens brake response time and braking distance.

- As long as the system detects rain or the wiper ON signal, the brake discs are repeatedly wiped at certain intervals to improve safety.
- ESC working
 - If there is a risk of skidding or backsliding when the vehicle starts on a slope, or if either drive wheel is idling, the ESC indicator flashes to indicate that ESC system is working.
- Disabling ESC
 - If the vehicle gets stuck in snow or mud, ESC may reduce power output from the motor to the wheels. In this case, you may need to turn off the system to get out of the jam.
- Turning off ESC
 - To turn off the ESC system, go to infotainment touchscreen → 📱 → **ADAS** → **Active Safety** → **ESC**. ESC also checks its operating status in real time. If ESC OFF switch is pressed while ESC system is working, the system will complete the active intervention control rather than executes the "shutdown" command immediately. ESC is disabled only after the intervention control is complete.
 - After ESC is turned off, some ESC functions may be re-enabled if you press the ESC OFF switch again or the vehicle speed exceeds the threshold (80 km/h). In order to prevent ESC from being turned off suddenly, ESC can be activated again only when it is not in a vehicle dynamic intervention state.



- Restarting ESC system
 - When the ESC system has been turned off, restarting the vehicle will automatically restart the ESC system.
- ESC system start and speed linkage
 - Although already turned off, the ESC system can start on its own if the vehicle becomes extremely unstable as the speed increases and exceeds the threshold of 80 km/h.
- When ESC system is activated
 - If the ESC fault indicator 🚗 flashes, drive with extra care to avoid accidents.
- When ESC system is disabled
 - Be careful when ESC is disabled, and drive at speeds suitable for road conditions. The ESC system ensures vehicle stability and its driving force. Never turn it off unless necessary.
- Replacing tires
 - Make sure all tires are of the same size, brand, tread pattern, and total load. In addition, be sure to inflate tires to the recommended pressure.
 - Neither ABS nor ESC will work properly if the vehicle is fitted with different tires.
 - For details on tire or wheel replacement, it is recommended to

contact a BYD authorized dealer or service provider.

- Tire and suspension handling
 - The use of any defective tire or modified suspension affects the driving safety system and may cause the system to fail.

Active Suspension Mode*

The active suspension mode function is used to adjust the softness of the suspension system. In different modes, the damping force curve of shock absorbers is intelligently adjusted according to vehicle speed and attitude. Drivers can choose between the soft and hard style of the suspension based on their preference.

- Go to the infotainment touchscreen →  → **Vehicle Settings** → **Intelligent Chassis** → **Active Suspension Mode**, and select **Comfort** or **Sport**.

Anti-lock Braking System (ABS)

- The ABS hydraulic system has two separate circuits, each running diagonally through the vehicle (left front wheel brake connected to the right rear wheel brake). If one circuit fails, two wheels can still be braked.
- ABS helps maintain the steering control by preventing the wheels from locking or skidding when brake is engaged suddenly or on slippery roads.

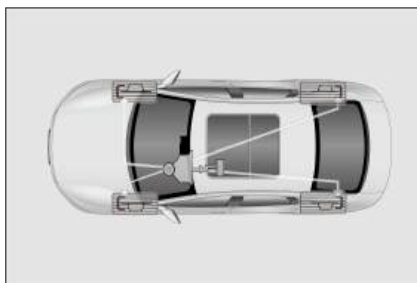

- When the front tires skid, there is no steering control, which means that the vehicle still moves forward even though the steering wheel is turned. ABS helps prevent locking and maintain steering control since pulsating prompt brake is much faster than human reaction.
- Never pulsate the brake pedal; otherwise, ABS may malfunction. While steering away from danger, a firm and steady pressure should always be maintained on the brake pedal for the ABS to work.
- When the ABS is working, the brake pedal will vibrate, which may produce noise. This is because the ABS is pulsating the brake quickly, which is normal.

Electronic brake force distribution (EBD)

- The EBD is an auxiliary function of ABS. Before ABS acts, if the skid rate of rear wheel is high, ABS adjusts the brake pressure of rear wheel for a smoother and more ideal brake force distribution.

WARNING

- ABS cannot work effectively under the following conditions:
 - Tires with inadequate grip are used (for example, excessively

 **WARNING**

worn tires used on snow-covered roads).

- The vehicle skids when driving at a high speed on slippery roads.
- ABS is not designed to reduce the braking distance of the vehicle. Always keep a safe distance from the vehicle ahead on:
 - Driving on slippery, muddy, sandy or snowy roads.
 - Roads with potholes or uneven roads.
 - Bumpy roads.

 **CAUTION**

- If the ABS fault warning light is still on while the braking system warning light is on, immediately park the vehicle in a safe place. It is recommended to contact a BYD authorized dealer or service provider.
- In this case, if brakes are applied, the ABS will not work and the vehicle will become extremely unstable.
- ABS does not reduce the time and distance required to stop the vehicle. This device only helps you control steering when braking. Please always keep a safe distance from other vehicles.
- ABS cannot prevent skidding caused by sudden direction change, such as trying to make a sharp turn or change lanes suddenly. Always drive carefully at a safe speed, regardless of road and weather conditions.

 **CAUTION**

- ABS does not prevent decrease in stability either. When applying the brake in an emergency, the steering should be moderate. A large or sharp turn during the driving can cause the vehicle to swerve into oncoming traffic or run off the road.
- When driving on wet or soft or uneven roads (such as waterlogged concrete roads, waterlogged epoxy painted roads, sandy roads, snowy roads), vehicles equipped with ABS may require longer braking distances than vehicles without ABS. In such cases, reduce the vehicle speed and keep a greater distance from other vehicles.

Other Main Functions

Interior Rearview Mirror

Automatic Anti-glare Interior Rearview Mirror

The automatic anti-glare interior rearview mirror is equipped with electronic anti-glare function, which automatically adjusts the lens color of the mirror according to the surroundings to reduce the interference of rear glare on the driver's field of vision.

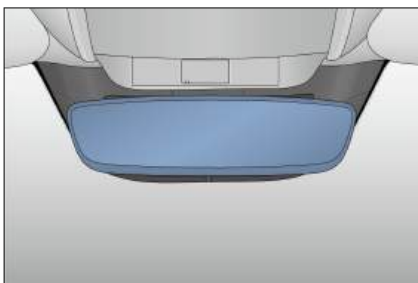

WARNING

- Do not hang heavy objects from the interior rearview mirror, or shake or drag it with force.
- When manually adjusting the interior rearview mirror, do not forcibly adjust the stuck mirror to avoid the mirror falling off.
- Do not adjust the rearview mirror while driving. This may distract your attention, causing personal injury or death from accidents.

Adjusting the Rearview Mirror Manually*

Move the interior rearview mirror up or down, left or right to a suitable position.

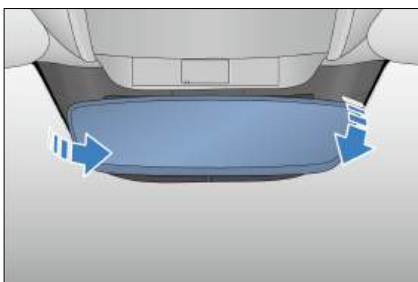

WARNING

- Adjusting the interior rearview mirror before driving. Do not adjust the rearview mirror while

WARNING

driving. This may distract your attention, causing accidents.

- Do not hang heavy objects from the interior rearview mirror, or shake or drag it with force.
- When manually adjusting the interior rearview mirror, do not forcibly adjust the stuck mirror to avoid the mirror falling off.

Side Mirrors

Use the associated switches to adjust the side mirrors to see the sides of the vehicle using.

- Selection switches: used to select the side mirror to be adjusted (see **P**).

REMINDER

- The power side mirror has the turning function upon reversal. When the vehicle is being reversed, the power side mirrors automatically turn down.
- Adjusting side mirrors before driving. Do not adjust the side mirrors while driving. This may distract your attention, causing accidents.

Folding Side Mirrors

Folding side mirrors manually

Push the outer edge of a side mirror to rotate it around the folding axis to the locked position.



Folding side mirrors with power

- Press the  button to fold the side mirrors with power. Press the button again to unfold the mirrors.
- Both side mirrors fold automatically when the anti-theft alarm system is armed, and extend automatically when the system is disarmed.



Wiper Blades

Inspect front/rear wiper blades for cracks or partial hardening at least every six months. If they are noted, replace wiper blades. Otherwise, the windshield will streak or will be left unclean after wiping.

CAUTION

- Do not open the hood when wiper arms are lifted, otherwise it may damage the hood and wiper arms.

Replacing Wiper Blades

With the ignition on, turn on the wiper service function by going to infotainment touchscreen → **Vehicle Health** → **Overhaul**. When the corresponding wiper service function is enabled, the wipers rotate out automatically for easy maintenance and replacement.

1. Pull up the wiper arm at the driver side, and then pull up the other at the passenger side.
2. Press the wiper lock button.
3. Hold the wiper blade and pull it out along the indicated direction.
4. When installing a new wiper blade, follow the reverse procedure.

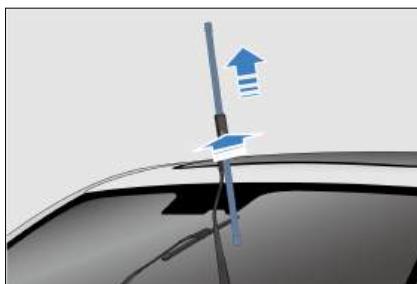

Snow Chains

- Snow chains are only for emergencies or areas where they are permitted by laws.
- Snow chains should be installed on front wheels. Be careful when driving the vehicle installed with snow chains on snow-covered roads. Use thin snow chains. Some snow chains may damage tires, wheels, suspensions, and the vehicle body. The recommended snow chains are no larger than 6 mm in thickness or diameter, which provides enough space between tires and other parts in the hubcap.

- Read the component assembly drawings and other instructions provided by the snow chain manufacturer carefully.
- Before purchasing and installing snow chains, consult a BYD authorized dealer or service provider where your vehicle was purchased.
- After snow chains are installed, be sure to travel at a speed below 30 km/h on snow-covered roads.
- In order to minimize wear of tires and snow chains, do not travel with snow chains on roads without snow.

**CAUTION**

- After snow chains were installed, the driving speed must not exceed 30 km/h or the speed limit specified by the snow chain manufacturer.
- Drive carefully, paying attention to bumps, potholes, and sharp turns that can cause the vehicle to bounce.
- For vehicles with snow chains, avoid sharp turns or braking with locked wheels, and slow down the vehicle before entering a curve to avoid accidents due to loss of control.
- Install the chains symmetrically and remove them immediately after driving on snowy or muddy roads.
- If an abnormal sound is heard from the snow chain, please stop the vehicle immediately to check whether the vehicle components such as suspension, body or brake lines are normal, and ensure that there is no contact between them and the snow chains.

05

IN-VEHICLE DEVICES

Infotainment System.....	142
A/C System.....	144
BYD App.....	152
Storage.....	153
Other Devices.....	155

Infotainment System

Infotainment Touchscreen

When the ignition is switched on, the initial screen is displayed for several seconds and the infotainment system starts to work. To better experience infotainment functions, such as apps and Internet calls, the system must be used after network connection.

- ① Infotainment touchscreen
- ② Scroll button



- Scroll up to turn volume up or down to turn volume down. Volume ranges from 0 to 39. A mute icon is displayed when the volume is 0.
- Press the scroll button to mute the sound and enter the screen saver screen or turn off the screen (set the screen saver through the infotainment touchscreen → **System Settings** → **Display**). Press the scroll button again to turn off the mute and turn on the screen.
- Press and hold the scroll button for three seconds to restart the infotainment system.

Reset to factory settings

- This function factory resets the infotainment system.

- During the process, do not touch any infotainment button or turn off the power supply, or errors may occur.
- The process takes two to five minutes.

WARNING

- Do not use a high-power inverter in the vehicle, as this may cause infotainment system malfunction.
- Do not format or root the device, as this may cause infotainment system or vehicle malfunction.
- In driving, please use the infotainment system in landscape mode wherever possible for your safety.

CAUTION

- To prevent damage to the touchscreen:
 - Touch the screen gently. If there is no response, remove finger from the screen, then touch it again.
 - Clean the screen with a soft damp cloth. Do not use any cleaning product.
- Using the touchscreen
 - When the screen temperature is low, the image displayed may be darker or the system may work slightly slower than normal.
 - The screen may be dark or difficult to see when you are wearing sunglasses. In that case, change the viewing angle or take off the sunglasses.
- Touchscreen buttons that are grayed out cannot be operated.



CAUTION

- The touchscreen interface shown here is for reference only.

Navigation Bar

: returns to the previous page or exits the program.

: returns to the homepage.

: goes to vehicle setting screen.

: splits screen if applications support.

: enables screen saver.

: shows recently opened applications.

: switches between landscape and portrait touchscreen modes.

Gestures and Responses

Gestures and associated system responses are:

- Tapping: opens applications, selects functions, clicks icons on the touchscreen, or types characters.
- Dragging: touching and dragging an icon, thumbnail, or preview to the target position to change its location.
- Swiping: operational on homepage and app screens.
- Double-tapping: zooms in or out an image.
- Spreading/pinching: zooms in or out an image with two fingers.
- Swiping down from the top of the touchscreen: open the shortcut menu.

- Swiping up from the bottom of the touchscreen: open the management center.

BYD Assistant

BYD Assistant is an intelligent voice assistant that responds to your voice commands, such as requesting navigation, playing music/radio, making a phone call, and controlling in-vehicle devices.

- Waking up BYD Assistant:
 - On the steering wheel, press the button.
 - On the infotainment touchscreen, tap .
 - Say the wake-up word: "Hi, BYD."
- Your voice commands can be recognized after system wake-up.
- Give any instructions.
 - This may be "Go home" (shortcut locations set), "Play music", "Make a call" (contacts data and Bluetooth connection required), "Set the temperature to 23°C", or "Turn on the seat ventilation for the driver". BYD Assistant then performs the recognized instruction.

Bluetooth Call

Connection



1. On Bluetooth Call screen, tap **Please connect Bluetooth** to establish connection.
2. Tap **Scan for devices** to search for available device.
3. Pair the available device, and make sure the pairing code displayed on your

phone is consistent with the code on the touchscreen.

4. Set Bluetooth when connection is complete.

Bluetooth Call

Go to the dialing screen when Bluetooth is connected.

- Tap **Contacts, Call log, and Missed calls**, or use dial keypad to make a call.
- Tap  to zoom in or out the dialing screen.
- Tap  to display or hide the dial keypad.
- In panoramic view screen, a small window pops up to inform driver of a call.

File Management

New folder

- Go to file management screen to create new folders. You can enter the folder name, and tap OK or Cancel to perform actions.
- Tap the top of the file management screen to change file sources.

Search

- Tap Search on the upper left corner and enter file names to search for target files.

Cut/Copy

- Touch and hold any file, select target files and operation (copy, move or delete), and then go to the edit status.

Rename

- Touch and hold any file, select Rename in dialog displayed, rename the selected file, and then tap OK.

Delete

- Touch and hold any file, select files, and then tap **Delete**.

Sort

- Files are sorted by name by default. You can also sort them by size, type, or time.

Attributes

- Touch and hold any file, select a file, and then tap Details to check its attributes.

A/C System

A/C

A/C Buttons

Front row A/C buttons

- ① AUTO
- ② A/C ON/OFF
- ③ Front windshield defroster

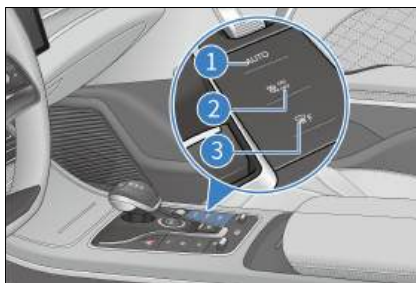

- To access the A/C setting screen, go to  → **Vehicle Settings** → **A/C**.

Fan speed reduction during calls

- Tap this button to enable this setting.
- Tap this button a second time to disable it.

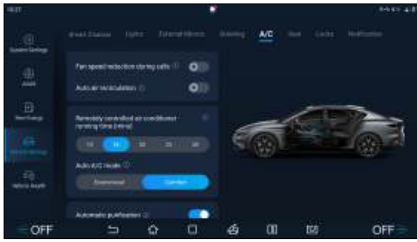

Auto air recirculation when parking

- Tap this button to enable this setting.
- Tap this button a second time to disable it.

Remotely controlled air conditioner running time (mins)

- Tap this button to set the time for remote A/C running.

Auto A/C mode

- Two options are available: **Economical** and **Comfort**.

Automatic purification

- Tap this button to enable auto purification function.
- Tap this button a second time to disable it.

A/C Operation Interface

Front-row A/C operation interface



- | | | | |
|---|--------------------------|----|---|
| 1 | A/C setting | 10 | Front windshield defroster |
| 2 | Air purification system* | 11 | Defroster for rear windshield & side mirrors* |
| 3 | Vent/Heating* | | |

- | | | | |
|---|-------------------------|----|---------------------------------------|
| 4 | A/C operation interface | 12 | Circulation mode |
| 5 | A/C ON/OFF | 13 | Ventilator |
| 6 | Auto mode | 14 | Front passenger's temperature control |
| 7 | Cooling | 15 | Driver's temperature control |
| 8 | Max cooling | 16 | Air distribution |
| 9 | Independent control | 17 | Fan speed control |

Rear control panel interface*



Automatic screen lock

- With the rear screen lock released, the rear control panel screen will lock automatically after a period of inactivity.

Unlocking the screen

- Tap the unlock button on the rear control panel to unlock the screen.
- When you tap any other button on the locked screen, the unlock button flashes to indicate that the screen is currently locked and the operation is invalid.
- The rear control panel does not display the unlock button when the automatic screen lock is deactivated.

! REMINDER

- When the rear-row lock button on the shortcut menu of the infotainment touchscreen is locked, buttons on relevant interfaces are not available.

! REMINDER

- Button operations on the rear control panel are invalid when the front windshield defroster is enabled.

Function Definitions

Function Definition

Auto mode

- After tapping this button, its indicator lights up, and compressor status, fan speed and air distribution can be adjusted automatically.
- The vehicle exits auto control if fan speed or air distribution is set, and other functions remain in auto mode except for those that have been operated.

A/C ON/OFF

- Tap this button to disable the A/C if it is ON.
- Tap this button to enable the A/C if it is OFF.



Max cooling

- Tap this button to switch the A/C to the maximum cooling control mode. The temperature is set to "Lo", the fan speed is set to the maximum, the recirculation mode is activated, and air is directed to face level.
- Tap this button again to exit.

Cooling

- Tap this button to activate the A/C compressor. The compressor then starts to work for cooling.
- Tap this button again to deactivate the function, and the compressor stops working.

Circulation mode

- Tap this button.  is displayed, and the circulation mode is recirculation.
- Tap this button for the second time.  is displayed, and the air inlet mode is fresh air mode.



REMINDER

- When the "automatic recirculation when parking" function is enabled, to ensure air quality in the vehicle and prevent the vehicle exhaust from entering the vehicle, the recirculation mode is switched on automatically after you shift into "P".

Ventilator

- Tap this button to activate A/C ventilation control. The outlet air is natural air.
- Tap this button again to exit.

Temperature controls

- A/C temperature regulation
 - Tap the upside arrow or slide it down to increase the temperature. Tap the downside arrow or slide it up to lower the temperature.
 - When the temperature is set to the lowest, "Lo" is displayed. When it is set to the highest, "Hi" is displayed.

Front windshield defroster

- Tap this button to enter the front windshield defrost mode, distributing air to the front windshield. The corresponding button indicator lights up.
- Tap this button again to deactivate and exit the front windshield defroster control mode. The corresponding button indicator turns off.

Defroster for rear windshield & side mirrors*

- Tap this button, and the heating panel in side mirrors will quickly clear the side mirrors. The function is automatically deactivated after 15-minute inactivity of the associated button.
- Tap this button a second time to disable the function.
- This function is not to be used to dry raindrops or melt snow.





REMINDER

- Using the side mirror electric heating defrosting function for a long time may cause the mirror to wear out faster. Turn off the



! REMINDER

defrost button when it is not needed.

Fan speed control

- Fan speed control
 - Tap the chosen position. The more bars illuminated, the faster the fan speed.
 - Tap  to set fan speed to level 1, and tap  to set to level 7.

Air distribution

- Tap an icon on the infotainment touchscreen to select the corresponding air distribution mode.
- You can turn on multiple air distribution modes at a time (up to three).
- Adjustments can be made according to the air supply illustration.
-  : Air flows to the face level.
-  : Air flows to the foot level.
-  : Air flows to the front windshield and side windows.

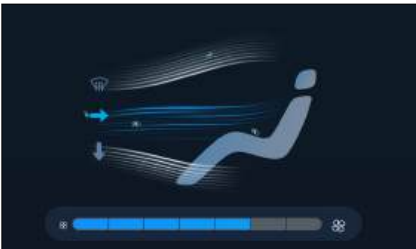

Usage Precautions

- To quickly cool down the interior after long exposure to sunlight, drive for a few minutes with the windows open.

to exhaust hot air and speed up A/C cooling.

- To speed up cooling, adjust the temperature to "Lo" and use the recirculation mode for a few minutes.
- Make sure that the air intake grille in front of the windshield is not blocked (for example, leaves or snow).
- Avoid blowing cool air onto the windshield in humid weather. The inner and outer temperature difference can cause glass fogging.
- Keep the space under the front seats clear to improve air circulation.
- In cold weather, run the fan at high speed for one minute to remove snow or moisture from the intake passage and reduce fogging.
- Use recirculation mode for a few minutes for quick heating in cold weather, and switch to fresh air mode to prevent fogging after cabin is heated up.
- In dusty or windy driving conditions, close all windows, switch on the recirculation mode, and turn on the A/C.
- In heating mode, press the compressor control button to light up the button (turning on the compressor), which can reduce airflow moisture.
- In the ventilation mode, the system introduces the natural wind from outside, which is suitable for spring and autumn.

! REMINDER

- A/C odor:
 - It is normal that there may be a damp and moldy smell just after the A/C is turned on. During the operation of the automobile

! REMINDER

A/C, A/C condensation often remains in the evaporator, and the wet evaporator can easily absorb dust, sweat, smokes, and other odors inside the vehicle. Condensation not blown dry promotes mold growth on the sunless and damp evaporator surface, which is very likely to produce unpleasant odors with fermentation over time.

- How to prevent A/C odors:
 - Turn off the A/C and ventilate with natural air before parking to keep the air inside the vehicle relatively dry.
 - Inspect, clean, or replace the A/C filter regularly.
 - Try to keep the cabin clean and fresh.
- If the odor persists after odor prevention methods are used, it is recommended to contact a BYD authorized dealer or service provider for repair.
- In order to reduce odors from the A/C, if the A/C is already turned on, the A/C blower may keep running for a while after the vehicle is powered off and locked. That is because the condensed water on the surface of the evaporator needs to be dried to prevent mold fermentation. It is normal for the A/C blower to start running automatically when you lock the vehicle. No need to worry about it.

A/C Vents

Side vent

- Toggle the vent stick ① to adjust the outlet angle of air flow.
- Turn the scroll button ② to adjust the size of the vent or to open/close the vent.

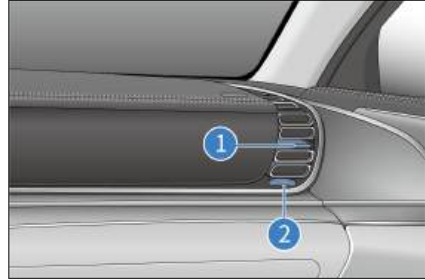

Center vent

- Toggle the vent stick to adjust the outlet angle of air flow or close the vent. When you adjust the stick to the far left and hear a click, the vent is closed.

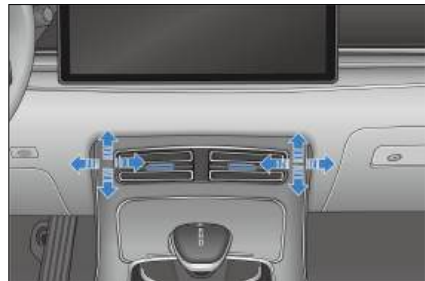

Rear vent

- Toggle the vent stick ① to adjust the outlet angle of air flow.
- Turn the scroll button ② to adjust the size of the vent or to open/close the vent.
- Toggle the right vent stick ③ to adjust the outlet angle of air flow.

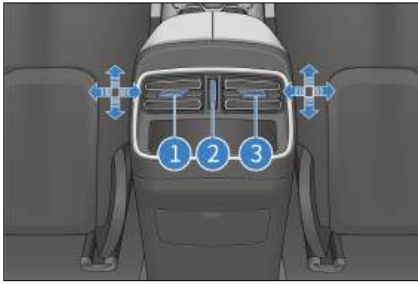

is turned on, the system thoroughly removes PM2.5 particles from the air blown into the cabin.

Air purification operation interface

On the infotainment touchscreen, tap **Air purification**. The air purification interface is displayed.

Air Purification System

The air purification system purifies airborne PM2.5 particles. When A/C



- | | | | |
|---|-------------------------------|---|--------------------|
| 1 | Air purification | 4 | PM2.5 detection |
| 2 | Outside PM2.5 value and level | 5 | Quick purification |
| 3 | Inside PM2.5 value and level | 6 | Anion* |

PM2.5 detection

Tapping this button lights it up and activates detection of real-time PM2.5 concentration inside/outside, which will be displayed on the infotainment touchscreen. The detection stops when the button turns off.

Quick purification

Activates or deactivates quick purification.

Anion*

Turns the anion generator on or off.

Outside/Inside PM2.5 value and level

- Displays the PM2.5 value and level outside/inside the vehicle.

Here is a reference of air quality grade:

Range of PM2.5 Values	Air Quality Grade
0-35	Good
36-75	Moderate
76-115	Detrimental to sensitive groups
116-150	Unhealthy
151-250	Very unhealthy
251-999	Hazardous

REMINDER

- The PM2.5 value detected by the on-board air purification (PM2.5) detector is the PM2.5 value in the air near the vehicle carrying the device in a short time, which should be different from the daily or real-time PM2.5 value declared by national and relevant government authorities.
- The frequency of PM2.5 detection should be reduced in the following environments:
 - Sandstorms and other such extremely harsh environments.
 - Cold regions (with ambient temperature below -20°C).
 - High humidity environments (relative humidity >90%).
 - Environments with a change in temperature (prone to condensation), such as driving

REMINDER

- in from a cold environment to a high-temperature indoor environment or parking lot.
- Running maximum air flow speed in recirculation mode can quickly reduce the concentration of fine particles in the air inside the vehicle.

Switching on A/C with Cloud Service App*

- Turning on the A/C: On the BYD app, tap **A/C ON**, adjust "Set temperature", "Duration" and "Circulation mode", and enter the password to enable A/C remotely.
- Turning off the A/C: Tap the "A/C OFF" button on the BYD APP control interface, and enter the password to disable A/C remotely.

- Presetting A/C operation: On the BYD app, tap **A/C schedule** → **Create Schedule**, set time, temperature, duration and circulation mode, and save the settings. The A/C will be turned on at the set time.

BYD App

About BYD App

- BYD app is a mobile application of Internet of Vehicle (IoV) developed by BYD independently. It allows you to control the vehicle remotely and check vehicle conditions, delivering cloud era experience of IoV.
- Search for "BYD" in Google Play or App Store to download and install BYD app.

Account Registration

App guidance and the following steps give instructions on signing up and logging in after BYD app installation.

1. Open the app, then tap **Sign up** to go to the registration screen.
2. Enter email address registered in BYD authorized dealer, tap **Send email** to receive verification code, and then enter the code in app.
3. Set your password in password setting screen to complete the registration, and then the homepage is displayed.

CAUTION

- Provide the email address registered at the BYD authorized dealer, or registration will fail.
- In the app, select a country or region on upper right corner of the screen. The default setting

CAUTION

depends on your phone setting. If it is not where you make the purchase, choose the right one, otherwise your data will not be accessible.

Vehicle Condition and Control

On the BYD app homepage, you can check vehicle information and corresponding control items.

1. The homepage shows remaining driving range, state of charge, abnormal information, driving condition, charging status, A/C status, door and window states, seat heating and ventilation states, and tire pressure.
2. Tap lock, unlock, light flashing & honking, or light flashing button to activate the corresponding function.
3. Turn on or off A/C on the app homepage, or tap the A/C card to perform other settings. See details in **P145**.
4. At the bottom of the homepage, check status of seats, doors, windows and tires on associated screens by tapping the corresponding icons.
5. If you have more than one vehicle under the same account, tap the vehicle name on the upper left corner to switch vehicles.

CAUTION

- The control function of the app is mainly for remote use. To use this function, ensure your phone and vehicle are connected to the Internet.

Individual Center and Vehicle Management

Tap "My Account" to go to the individual center.

- **Vehicle management:** changes vehicle name and license plate number.
- **Account and security:** recovers or changes your password.
- **Settings:** sets message reception, automatic login, and other items.
- **About:** includes privacy policy and information to contact us and give feedback.

Storage

Glove Box

- To use the glove box, unlock it with a mechanical key and then pull the glove box lid.
- Push the lid up to close it.

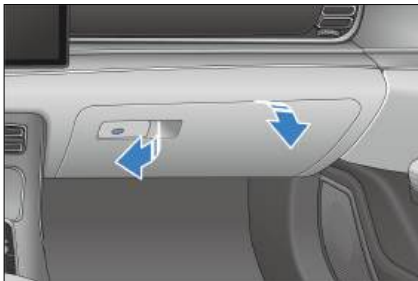

! REMINDER

- To reduce risk of injury in the event of an accident or emergency braking, keep the glove box closed while driving.

Cubby Box

To use the cubby box, press the switch on the front of cubby box to open it.



! REMINDER

- Keep the bill box closed while the vehicle is in motion.

Cup Holder

Front Seat Cup Holder

- The cup holder is used to securely hold cups, movable ashtray, beverage can, etc.
- Tap the cup holder cover to open it automatically.

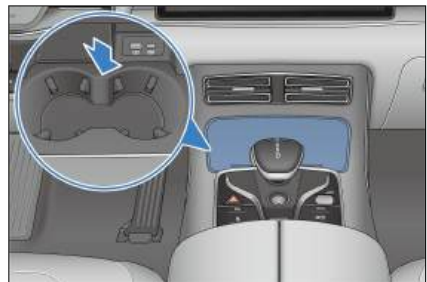

! REMINDER

- The cup holder should hold a cup or beverage can securely to avoid

REMINDER

any liquid spilling from the cup or can; otherwise, the USB ports may be damaged.

Rear Seat Cup Holder

1. Flip the rear seat armrest.



2. Tap the cup holder cover to open it automatically.

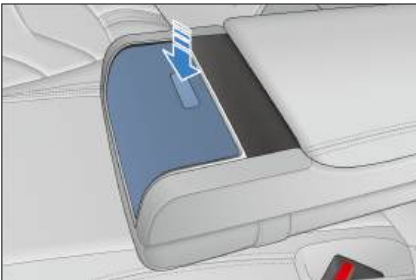

CAUTION

- When using the cup holder, do not start or brake the vehicle suddenly to prevent liquid spillage and burn you or other passengers.
- Do not place an open cup or untightened beverage bottle in the cup holder, so as to avoid liquid spillage when you are opening and closing the doors and driving.

CAUTION

- To ensure safe driving, the driver is strictly prohibited from taking the cup out or placing it in the cup holder while driving.

Glasses Case

Press the lid of the case to open it.



Door Bins

Door bins are available on all doors to hold cups and canned beverages.



Bill Box

Tap the lid to open the bill box.

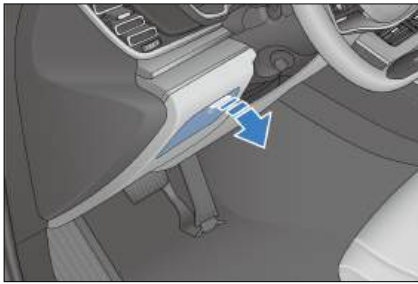

Seatback Pockets

- There are seatback pockets at the back of the front seats for storing magazines, newspapers, or similar objects.

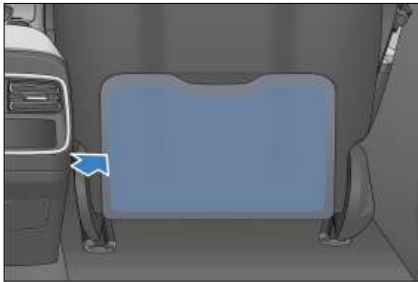

Other Devices

Sun Visor

- ① Sun visor
- ② Vanity mirror

- The sun visor is located above the driver seat and front passenger seat. To block sunlight from the front, pull the sun visor down.
- To block sunlight from a side, remove the swivel sleeve from the fixed support and turn the visor towards the side window.

- When a vanity mirror is installed, flip down the sun visor and slide the mirror cover for use.

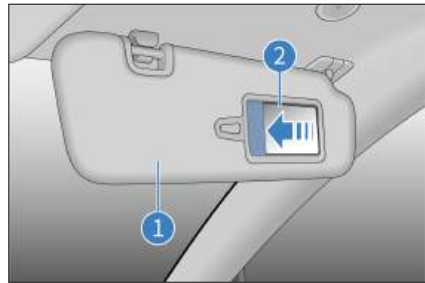

! REMINDER

- Correct use of the sun visor improves driving safety and comfort.

Grab Handles

- ① Hook: Do not hang any heavy objects on the hook to avoid damage to the hook.
- ② Grab handle: Pull the grab handle down for use. The handle returns to its original position when released.

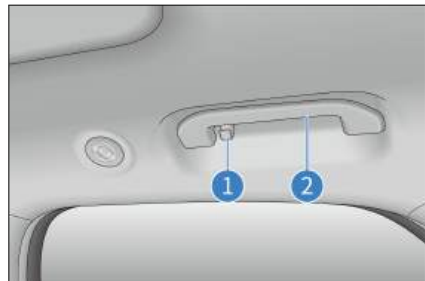

! CAUTION

- Do not hang any heavy objects from the grab handles.

⚠ CAUTION

- Do not hang items on hooks and grab handles while the vehicle is in motion.

12V Auxiliary Power

- It is used for accessories with 12V DC working voltage and no more than 10A working current.
- The 12V auxiliary power is available only when the ignition has been switched on. Lift the cover to use it.



⚠ CAUTION

- To prevent fuses from blowing, the power consumption must not exceed 12V/120W of total vehicle load.
- To prevent draining the low-voltage battery, do not use the 12V auxiliary power supply for a long time when the drive motor is not running.
- When the 12V auxiliary power is not in use, close its cover. Do not insert any object other than a suitable plug into the 12V auxiliary power socket or let any liquid ingress the socket, as electrical failure may result.

USB Ports

USB charge ports can only be used when the ignition is on.

- Only charge ports are provided under the front cup holder cover.

- ① USB charge port
- ② Type-C fast-charge port



- The cubby box contains USB ports.

- ① USB data transmission port
- ② USB charge port



- The infotainment system is compatible with USB storage devices up to 128GB. It is not compatible with some USB devices on the market.

⚠ CAUTION

- It is recommended to use USB storage devices up to 128GB with FAT32 format.

CAUTION

- Do not use substandard or special USB storage devices to avoid damaging the infotainment system or data in the USB device.
- Only USB charge ports are provided in the rear-row armrest.

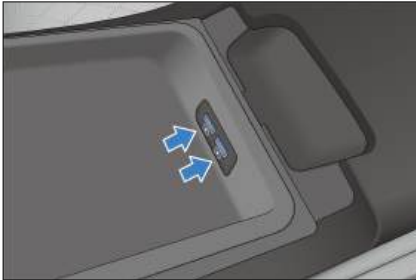

CAUTION

- Incompatible cards may not be recognized and read by the infotainment system.

Wireless Phone Charger

- On the infotainment touchscreen, slide down the shortcut menu and light up the wireless charger icon.



SD Card Slot

An SD card slot is located in the cubby box.



- For this infotainment system, TF cards (also called Micro-SD cards), up to 128GB and at least Class 10 and FAT32, can be used to read data such as videos and songs.

CAUTION

- Insert the card correctly.
- Since 64GB and 128GB TF cards in market are generally non-FAT32

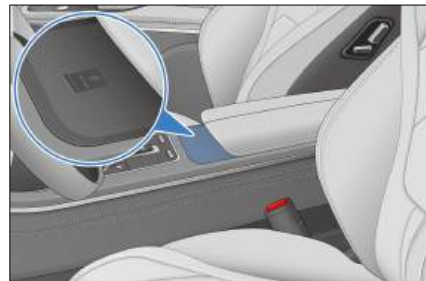

- Wireless phone charging uses a coil to transmit electrical energy to a phone battery through electromagnetic wave induction so that the phone can be charged without a cable connection.

 **CAUTION**

- If a metal item is found between the device and the charging rubber pad during charging, do not remove the metal item with bare hands immediately to prevent burning.
- For better charging, the center of the phone coil must be aligned with the center of wireless charger (indicated with text in the charging area).
- Prevent any fluid from coming into contact with the charger area. The wireless charger will malfunction if water enters the wireless charger via the gap around the rubber mat.
- Charging may stop at high temperatures, and will resume once the temperature drops.
- The wireless phone charging system can charge Qi-certified phones, and non-Qi-certified phones are not guaranteed for normal charging.
- BYD makes no commitments for problems caused by external wireless charging coils. Please use with caution.
- To avoid burning cards with chips, such as bank cards, do not place them between the phone case and the phone during charging.

 **REMINDER**

- Only one phone can be charged at a time.
- A phone case that is too thick may prevent charging.
- On bumpy roads, the wireless phone charging may intermittently stop and then resume.
- Try to ensure that the surface on which a mobile phone is placed is parallel to the charging module. If the phone moves from the wireless charger area and stops charging, move it back.
- If the phone cannot be charged properly, ensure that there are no foreign objects in the wireless charger area, or wait for the wireless charger area to cool down before trying again. If it is still impossible to charge the phone, contact a BYD authorized dealer or service provider.
- After power-off, if the phone is still charging and the driver's door is opened, the instrument cluster sounds an alarm and the message "Please take your cell phone with you" is displayed for five seconds.
- Ensure your smart key is more than 25 cm away from the wireless charger area when the wireless charger system is working.
- To avoid wireless charger dysfunction or even accidents, do not place coins, metal keys, metal rings, or other articles containing metal in the wireless charger area together with the phone.



REMINDER

- To avoid damage to the charger area, do not place heavy objects on it.
- If the phone wireless charger system is faulty and does not work properly, it is recommended to contact a BYD authorized dealer or service provider.
- BYD will not assume any responsibility for any problems caused by improper use. If the product is disassembled or modified, the free warranty will be terminated.
- For safety reasons, do not leave an unattended phone being charged in the vehicle.
- For safety reasons, refrain from checking phone charging status while driving.

06

MAINTENANCE

Maintenance Information.....	162
Regular Maintenance.....	164
Self-Maintenance.....	169

Maintenance Information

Maintenance Cycle and Items

Maintenance Plan

- The maintenance plan is designed to ensure stable driving, failure reduction, safe and economical driving.
- The maintenance schedule lists all the maintenance items that are necessary to keep the vehicle in optimum condition at all times.
- The items in the maintenance schedule are important and need to be maintained according to the time interval.
- Hoses with any degradation or damage should be replaced immediately. Rubber hoses (for systems such as A/C, heating, and braking systems) must be checked by professional technicians according to the maintenance schedule.

Maintenance Schedule Requirements

The vehicle must be maintained according to the regular maintenance schedule.

If the vehicle is operated primarily under one or more of the following special conditions, certain maintenance items need to be performed more frequently.

- Road conditions
 - Muddy, sandy, or snowy roads.
 - Dusty roads
- Driving conditions
 - Use of towed trailer, camping trailer, or roof rack.
 - Within 8 km, repeated short distances are driven and the outside temperature is below freezing.
 - Long idling and/or long distance driving at low speed, for example, using the vehicle as a police car, taxis or using it for transporting goods.

Maintenance Schedule

Vehicle maintenance is performed based on the mileages or months, whichever comes first.

Item	Interval
Brake friction block and disc	Check every 24 months or 30,000 km
Brake piping and hoses	Check every 24 months or 30,000 km
Steering wheel and tie rod	Check every 24 months or 30,000 km
Drive shaft boot	Check every 24 months or 30,000 km
Ball pin and boot	Check every 24 months or 30,000 km

Item	Interval
Front and rear suspensions	Check every 24 months or 30,000 km
Tire condition and inflation pressure, incl. TPMS	Check every 24 months or 30,000 km
Tire wear (Check front and rear wheel alignment when tire uneven wear is greater than 2 mm)	Check during maintenance and rotate when necessary; Under severe working conditions, check more frequently and rotate when necessary
EPS corrosion and foreign materials on or ablation of connectors, including wiring harness GND point	Check every 24 months or 30,000 km
Coolant level in expansion tank	Check every 24 months or 30,000 km
Brake fluid	Check every 24 months or 30,000 km
Bumps or deformation of the high-voltage battery tray, crash bar, shield, and explosion-proof valve*, and powertrain leaks	Check every 24 months or 30,000 km
A/C filter*	Check every 24 months or 30,000 km. In severe driving conditions, check every six months and replace if necessary
Drive motor coolant	Replace the long-acting organic acid coolant every six years or 90,000 km
Brake fluid	Check during maintenance and replace every 24 months or 30,000 km
Gear oil in the transmission	Replace the gear oil and filter at 24 months or 30,000 km for the first time, and every 24 months or 48,000 km afterwards

Notes: When checking Item 1, replace chassis parts in a timely manner if any abnormal damage is found.



CAUTION

- Brake friction pads and discs need to be checked at different intervals and more frequently in severe weather conditions, such as extremely cold regions like Norway, Finland and Iceland.



REMINDER

- To keep the high-voltage battery in optimal condition, please fully charge and discharge the vehicle regularly (at least every six months or 72,000 km, whichever comes first) for battery self-calibration. You can also contact



REMINDER

a BYD authorized dealer or service provider for capacity testing and calibration.

Severe driving conditions refer to:

- Frequent driving in dusty areas or frequent exposure to salt-laden air.
- Frequent driving on bumpy, puddled, or mountain roads.
- Driving in cold weather.
- Frequent and sudden braking.
- Frequent use of a towed trailer.
- Use as a taxi.
- Driving in congested urban areas at temperatures above 32°C for more than 50% of total travel time.
- Driving at speeds over 120 km/h at temperatures above 30°C for more than 50% of total travel time.
- Frequent driving with full loads.

Regular Maintenance

Regular Maintenance

Vehicle Servicing

- Pay attention to vehicle performance, sound changes, and visual evidence that indicates service is required. Under any of the following circumstances, the vehicle may need to be adjusted or repaired. Therefore, you are recommended to send the vehicle to a BYD authorized dealer or service provider as soon as possible:
 - Motor start produces unusual noises.

- Coolant remains overheated, is stagnated or leaks.
- Motor jams and produces unexpected noise.
- The motor runs with excessive vibration.
- The motor fails to get started.
- Electric assembly leaks oil.
- Electric assembly emits odors.
- Power declines significantly.
- Water leaks from under the vehicle (A/C condensate is normal).
- Tire deflates; tires make excessive noises at turns; tire wear is uneven.
- Vehicle leads to one side when driving straight on a flat surface.
- Suspension unit movement leads to unusual noises.
- Loss of braking effect; sponge feeling on the brake pedal or clutch pedal; pedal almost contacts the floor; vehicle leads to one side when braking.
- Motor coolant temperature remains high.
- Battery capacity decreases significantly.
- High battery temperature or overheat protection persists, or there is no power output.



WARNING

- Do not continue driving a vehicle that has not been inspected, as this may result in serious vehicle damage and personal injury.

Vehicle Corrosion Prevention

The most common causes of vehicle corrosion are:

- The underbody of the vehicle is covered in salt, dust, or moisture.
- The vehicle or some of its parts are exposed to high humidity and high temperature for a long time.
- The paint layer or underlayer is scratched by minor collision or by stones and gravel.

The following rules should be observed to prevent vehicle corrosion:

- Wash the vehicle frequently.
 - If driving on saline roads in winter or living in coastal areas, wash the landing area of the vehicle at least once a month, and clean the chassis and hubcap with a high-pressure water jet or steam to reduce corrosion. Wash the chassis thoroughly after winter.
- Check vehicle paint and trims.
 - Any chip or crack found on the paint must be repaired immediately to prevent corrosion. If fragments or cracks peel off from the metal surface, it is recommended to go to a BYD authorized dealer or service provider for repair.
- Check cabin interior.
 - Moisture and dust buildup under the carpet can cause corrosion. Check the undersides of carpets frequently to make sure these areas are dry.
 - Special care should be taken when the vehicle is transporting chemicals, detergents, fertilizers, salt, and other substances. Such substances should be kept in appropriate containers for

transportation. If spillage or leakage is found, clean immediately and keep dry.

- Use fenders.
 - Fenders protect vehicles in saline areas or on gravel roads. The bigger and closer to the ground the fender, the better.
- Park in a well-ventilated and dry area.

Paint Maintenance Tips

- Do not perform secondary painting if there are no obvious scratches on the finish, so as to prevent mismatch or color incompatibility.
- When the vehicle is not used for a long period, it should be parked in a garage or a well-ventilated place, and special body cover should be used in winter. Choose a shady place for parking temporarily.
- Prevent strong impacts, knocks, or scratches on the paint. If the paint is scratched, dented or if it peels, it should be repaired in time, preferably by professional auto beauty provider.
- Do not touch the paint with a greasy hand or cloth. Do not place greasy tools or rub with organic solvents on the vehicle body so as to avoid chemical reactions.
- The vehicle must be waxed once a month or whenever water resistance performance of the vehicle degrades and be taken to an auto beauty provider for maintenance once every three months.
- High quality polish and wax must be used. If body finish is severely weathered, use a car cleaning polish in addition to the wax. Carefully follow the manufacturer's instructions and precautions. Chrome finish should be

polished and waxed as well as painted finish.

CAUTION

- When the vehicle is repainted and placed in a high-temperature paint waxing workshop, the vehicle's plastic bumper must be removed to avoid damage caused by high temperatures.

Exterior Cleaning

- The vehicle must be cleaned in time under the following circumstances, which can cause peeling of paint layer or corrosion of the vehicle body and parts:
 - Driving along the coast.
 - Driving on a road with antifreeze.
 - Driving on roads covered with coal tar.
 - Resin, bird droppings, or insect carcasses are stuck on the vehicle.
 - Driving in areas with a large amount of smoke, soot, dust, iron filings, or chemicals.
 - The vehicle is visibly soiled by dust or mud.
 - After raining.

Manual Vehicle Washing

Before washing the vehicle, park it in the shade, and wait for the vehicle to cool down sufficiently.

1. Hose off loose dirt, including all mud or road salts at the bottom of the vehicle and on wheel pits.
2. Wash the vehicle with neutral agents, the mixing of which should be carried out according to the manufacturer's

instructions. Soak a soft cloth with cleaning solution and gently wipe it down along the direction of the water flow. Do not wipe in a circular motion or horizontally.

3. Rinse well—Dried washing agent forms markings. After washing the vehicle in hot weather, rinse all parts properly.
4. Dry the vehicle with a clean soft towel to prevent stay water marks. In order to prevent scratching, do not rub or apply excessive force on the paint.

REMINDER

- Do not use any strongly alkaline washing powder, soapy water, detergents, de-waxing detergents or organic substance (gasoline, kerosene, volatile oil, or strong solvent) to clean the vehicle.
- When cleaning the combination lights, do not wipe their surface with chemical solvents such as gasoline, alcohol, lacquer thinner, thinner, and carbon tetrachloride. Doing so can cause the combination light casings to crack.
- It is recommended that vehicles traveling in coastal or heavily polluted areas be washed once a day.
- When washing the vehicle, make sure that the high-pressure water jets are at a sufficient distance from the vehicle, and do not aim them directly at the sealing strips, to prevent high pressure from distorting and even damaging the strips and water from leaking into the vehicle.
- Do not use blades or gasoline to remove hard dirt from the vehicle body. The plastic wheel trim is

REMINDER

easily damaged by organic matter. If any organic matter splashes on the vehicle trim, remove it with water and check whether the trim is damaged. Please replace any seriously damaged plastic wheel trim in a timely manner. Otherwise, the trim may fall from the wheel during vehicle movement and cause an accident.

- Do not use abrasive cleaning agents to scrub the bumper.
- Clean polished metal parts with carbon cleaner and wax them regularly for protection.

Automatic Vehicle Washing

When choosing an automated car wash service, be aware of certain types of brushes, unfiltered rinsing water, or machine-specific rinsing procedures that may scratch the paint and affect its gloss and durability, especially for darker colors. Before washing the vehicle, it is best to consult the staff of the car wash service provider to understand which washing procedures are the safest for the paint finish.

Interior Cleaning

REMINDER

- Prevent direct water splash onto the dashboard or floor when washing the vehicle, as these may cause electrical faults.
- In order to prevent corrosion, do not wash the vehicle's floor.

Carpet

- Clean carpets with a good foam detergent.
- Use a vacuum cleaner to remove as much dust as possible. Several types of foam detergents can be used. Some are in spray cans, and the others are powders or liquids, which produce foam when mixed with water. Clean the carpets with foam soaked sponge or a brush, scrubbing in a circular motion.
- Do not use plain water, and keep the carpets as dry as possible.

Seat Belts

- The seat belts can be cleaned with neutral soapy water or lukewarm water.
- Scrub the seat belts with a sponge or soft cloth. Check the seat belts for excessive wear, tear, or cut marks.

CAUTION

- Do not clean the seat belt with colorant or bleach. These substances may decrease the seat belt's strength.
- Do not use any seat belt that is not dry.

Doors and Windows

- Doors and windows can be cleaned with any ordinary detergent.
- Check the door brakes regularly. If a door brake lever is found with visible dust accumulation, wipe it with a wet soft cloth.

 **CAUTION**

- When cleaning the inside of the rear windows, take care not to scratch or damage electric heating wires or junctions.

A/C Control Panel, Car Speakers, Dashboard, Control Panel and Switches

- Clean the A/C control panel, car speakers, dashboard, control panel and switches with a wet soft cloth.
- Wipe dust off gently with a clean soft cloth soaked in lukewarm water.

 **CAUTION**

- Do not use organic substances (for example, solvents, kerosene, alcohol, and gasoline) or acid or alkali solutions. These chemicals can cause discoloration, staining, or flaking.
- Please confirm that the detergent or polishing agent to be used does not contain the above substances.
- If a new liquid washing agent is used, do not splash it onto the interior surface of the vehicle, because it may contain the above substances. If there is any spillage, immediately clean it thoroughly.

Leather

- Leather trimmings can be cleaned with a neutral detergent for woolen.
- Use a soft cloth with a neutral detergent solution to wipe off the dust, and then use a clean, wet cloth to wipe the remaining detergent thoroughly.
- If leather gets wet, wipe it with a clean soft cloth and air dry it in a cool, ventilated place.

- For any questions about vehicle cleaning, please consult a local BYD authorized dealer or service provider.

 **CAUTION**

- If dirt cannot be cleaned off using a neutral detergent, clean it with a detergent that does not contain organic solvents.
- Do not clean leather with any organic material such as volatile oil, alcohol, gasoline, acid or alkali, as these will cause discoloration.
- Do not clean leather with a nylon brush or synthetic fiber cloth, as these may scratch the fine patterns on the leather surface.
- Mold may grow on dirty leather trimmings. Special care must be taken to avoid oil stains and trimmings must always be kept clean.
- Prolonged exposure to sunlight will cause leather to harden or shrink, so the vehicle should be parked in a shady and cool place, especially in the summer.
- In hot weather, avoid placing vinyl or waxy items on the trimmings, as these may stick to leather in high temperatures.
- Improper cleaning of leather trimmings may cause discoloration or spots.

Real Wood Trims

- It is recommended to wipe off the dust with a soft dry cloth every day to maintain normal gloss of the white ash. Do not wipe with a hard cloth or with acidic or alkaline cleaning products, which can damage the topcoat on the white ash.

- Strictly prevents chemicals (perfume, alcohol, cosmetics, tea, mineral water, grease, etc.) from contaminating real wood trims. These chemicals could lead to cracking or bonding gap of real wood trims.
- In case of contamination, wipe immediately with paper towel or dry cloth to reduce chemical damage to real wood.

Electroplated Trims

- It is recommended to wipe the dust from the trims with a soft towel to maintain normal gloss of the electroplated layer. Do not wipe directly with a hard cloth or with acidic or alkaline cleaning products.

Self-Maintenance

Self-Maintenance

Self-Maintenance Precautions

- If maintenance is to be carried out by the owner, be sure to follow the correct steps specified in this section.
- Note that improper and incomplete maintenance will affect the use of the vehicle.
- This section only lists instructions on simple maintenance items that can be done by the owner. However, there are many items that must be done by qualified technicians with special tools.
- Special care must be taken in maintaining vehicles to prevent accidental injuries. Make sure to obey the followings:



CAUTION

- Beware of short circuits, as some circuits and vehicle components carry high current or voltage.
- If coolant overflows, wipe it with a dry cloth or tissue to prevent damage to components or vehicle paint.
- If brake fluid overflows, rinse it with water to prevent damage to components or vehicle paint.
- When replacing wiper blades, do not allow the wipers to scratch the glass surface.
- Before closing the hood, check whether any tool or wipe cloth is left in the engine compartment.
- When working inside or under the vehicle, always wear goggles to protect your eyes against flying or falling objects or splashing liquid.
- As brake fluid may damage the skin or eyes, be careful when filling it. If your skin or eyes are exposed to brake fluid, immediately flush with clean water. Seek medical attention immediately if discomfort persists.

Checks

The following items should be checked according to usage or specified mileage:

- Coolant level - Check the expansion tank coolant level at each charge.
- Windshield washer fluid - The residual amount of washer liquid in the tank should be checked monthly. When washer liquid is frequently used, the residual amount of liquid should be checked at each charge.

- Windshield wiper - Check wiper conditions monthly. If the wiper does not work, check it for wear, cracking, or other damage.
- Brake fluid level - Check the level monthly.
- Brake pedal - Check whether the brake pedal is operating properly.
- EPB switch - Check whether the switch is functional.
- Low-voltage battery - Check battery conditions and check for terminal corrosion monthly.
- A/C system - Check the operation of A/C units weekly.
- Tires - Check tire pressure monthly. Check tread wear and whether there are foreign bodies embedded.
- Windshield defrosters - Check the defroster vent monthly.
- Lights - Check the condition of headlights, position lights, tail lights, high mount brake light, turn signals, rear fog lights, brake lights and license plate light monthly.
- Doors - Check whether the trunk lid and all other doors (including rear doors) can be opened freely and locked securely.
- Horn - Check whether the horn is functioning properly.

REMINDER

- Do not continue driving a vehicle that has not been inspected, as this may result in serious vehicle damage and personal injury.

Lights

Headlight adjustment

- Headlights are aligned before vehicle delivery. If the vehicle carries heavy load frequently, headlights may need to be realigned. It is recommended to have the headlights aligned by a BYD authorized dealer or service provider.

Fogging of lights

- Combination lights, tail lights, and turn signals on the side mirrors may become foggy after heavy rain or cleaning. This is similar to condensation on the side window during rain. It does not mean any problem with your vehicle.
- The lights are relatively enclosed and narrow spaces. The temperature is very high when they light up (the mask and reflector could be burned and deformed easily), so they need heat dissipation. There are heat dissipation holes on the lamp housing for convection. The greater the temperature difference is, the more active the convection is. During the convection, the moisture in the air inevitably enters a lamp. Factors such as exposure to sunlight, convection, and bulb heating can cause the moisture in the air to condense into fog or water beads easily on the lamp surface at low temperatures. This is called fogging of lights.

WARNING

- The headlight bulb becomes very hot when illuminated. Grease, sweat, or scratches on the surface of the bulb glass cause the bulb to overheat and break.

REMINDER

- If fog presents inside the headlight and inside the turn signals on side mirrors, it may be due to high air humidity or significant



REMINDER

temperature difference between the vehicle and its surroundings. In that case, turn on the headlight or turn signal while driving. The fog will evaporate after a short period of driving.

- If there is a noticeable amount of water inside the lights, it is recommended to drive the vehicle to a BYD authorized dealer or service provider for maintenance.

Sunroof Maintenance

- Wipe off dust or sand on the outer sealing strips of the sunroof with a damp cloth to avoid scratches, which may reduce sunroof sealing performance.
- Wipe off dust or sand on the molding edges of the front glass with a damp cloth to avoid scratches, which may reduce sunroof sealing performance.
- Clean the rails on both sides and the front channels frequently to avoid the accumulation of foreign materials like dust, sand, and leaves, and prevent such debris from blocking drainage holes, which could result in poor drainage of the sunroof.
- When washing the vehicle, make sure that the high-pressure water jets are at a sufficient distance from the vehicle, do not aim them directly at the sealing strips, to prevent high pressure from distorting even damaging the strips and water from leaking into the vehicle.
- The sunroof freezes easily in winter. Forcibly opening the frozen sunroof will damage sealing strips or other parts. Instead, warm up the vehicle and turn on the A/C system to

accelerate the melting of snow and ice on the sunroof. Try to open the sunroof after the temperature inside reaches a certain level. Dry the residual moisture on the sunroof to prevent it from freezing.

- Do not open the sunroof fully on extremely bumpy roads. Vibration between the sunroof and the rail may deform related parts and even damage the motor. In addition, do not open the sunroof when it rains or the vehicle is being washed.
- Clean the front of rear glass (with the front glass fully opened) frequently to avoid the accumulation of foreign materials like dust, sand, and leaves, and prevent such debris from blocking drainage holes, which could result in poor drainage of the sunroof.

Vehicle Storage

- If the vehicle needs to be parked for a long time (more than a month), the following preparations should be made. Proper preparation helps prevent degradation and ensure easy use of the vehicle. If possible, park the vehicle indoors.
- Charge the vehicle on time.
- Thoroughly clean and dry the body surface.
- Clean the interior of the vehicle to ensure that carpets and mats are completely dry.
- Release the parking brake and set the gearshift lever in parking gear.
- Open one window slightly (if the vehicle is stored indoors).
- Disconnect the negative terminal of the low-voltage battery.

- Pad the front wiper arm with a folded towel or cloth to keep it out of contact with the windshield.
- To reduce adhesion, apply silicone lubricant to all door seals and body wax to the painted surface where the door seals meet.
- Cover the vehicle body with a breathable covering made of a "porous material", such as cotton. Non-porous materials, such as plastic sheeting, can build up moisture and damage the paint.
- If possible, start the vehicle regularly (preferably once every month). If the vehicle has been parked for a year or more, go to a BYD authorized dealer or service provider for comprehensive maintenance.

Hood

Opening and Closing the Hood

1. Pull the handle on the left under the dashboard twice. The hood unlocks and opens slightly.

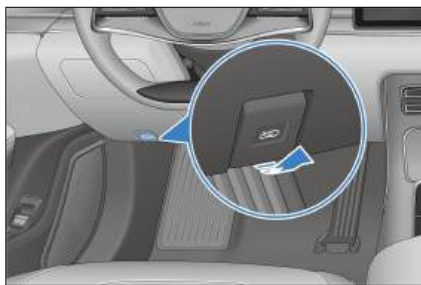

2. To open the hood: Raise the hood to an appropriate height; then it will automatically rise to the open state.



3. To close the hood: Pull the hood down to a certain height, push it down with a little force until it is half-locked, and then slowly press the blue area in the picture with both hands until the hood is fully locked and closed. Keep your hands at a certain distance and do not press the ridges.
4. After closing the hood, check whether the latch is securely locked.

CAUTION

- Ensure that the hood is closed and locked firmly. Otherwise, the hood may suddenly open during driving, resulting in an accident.
- Do not force down the hood.
- Do not close the hood with one hand, as this may concentrate the force in one area and cause damage to the hood.
- Do not press the front edge of the hood to prevent damage to the vehicle.

Cooling System

- The liquid level in the coolant expansion tank is required to be between the Maximum(MAX) and Minimum(MIN) lines.



! WARNING

- Before opening the coolant expansion tank cap, make sure that the motor, high-voltage electronic control assembly, expansion tank cap and radiator are all cooled down.
- Opening the coolant expansion tank when the motor has not yet fully cooled down may cause coolant to squirt out, resulting in severe burns.

! CAUTION

- It is recommended to go to a BYD authorized dealer or service provider for adding the coolant.

Braking System

- Check the level in the fluid tank monthly, and change the brake fluid according to the travel time and mileage specified in Maintenance Schedule.
- Be sure to use the brake fluid of the same specifications as the original brake fluid, and different types of brake fluid cannot be mixed.
- It is required that the level in the fluid tank should be between Maximum(MAX) and Minimum(MIN) marks.

- If the level is at or below the Minimum(MIN) mark, check if the braking system leaks and the brake friction plates are worn.



Washing System

- During normal use, check the liquid level of the windshield washer reservoir at least monthly.
- If the windshield washer is used frequently, the level of the washer reservoir should be checked more frequently.
- High quality windshield washer fluid should be added to improve stain removal and prevent freezing in cold weather.

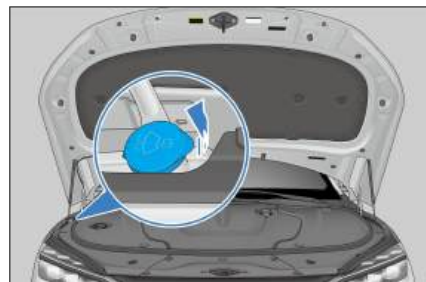

- When you add washer fluid to the fluid reservoir again, use a piece of clean cloth dipped with windshield washer fluid to clean the windshield wiper blade, which helps keep the blade edge in good condition.

CAUTION

- Do not inject vinegar-water solution or acid solution into the windshield washer fluid reservoir.
- It is recommended to use certified windscreen washing fluid having a pH value from 6.5 to 10.

A/C System

- The A/C system is a closed system, and any important maintenance work should be performed by professionals from a BYD authorized dealer or service provider.
- The following practices help ensure that the A/C system works effectively.
 - Check the radiator and A/C condenser regularly.
 - Remove leaves, insects, and dust from the front surface of the A/C system. These deposits hinder the air flow and reduce the cooling effect.
 - In cold months, turn the A/C on once a week for at least 10 minutes to circulate the lubricating oil in the refrigerant unit.
- If A/C cooling efficiency decreases, go to a BYD authorized dealer or service provider for maintenance.

CAUTION

- Whenever the A/C system is maintained, the maintenance station should use a refrigerant recycling system. Such systems recycle refrigerant to avoid environmental pollution caused by directly discharging refrigerant.

Wiper Blades

The blade strip, made of synthetic rubber, is a vulnerable part. Various service environment of the vehicle and usage habits of drivers can damage the blades. Therefore, please observe the following to ensure the service life of blades and driving safety:

- Do not use a blade to remove ice from the windshield surface. Use a customized ice scraper.
- Do not scrape the windshield surface if it is dirty, greasy or waxy.
- Keep the windshield surface clean. Do not scrape dust, sand, insects, or foreign bodies on the windshield surface.
- During vehicle washing and body paint maintenance, there is no need to wax the windshield, as the wax layer reflects light in bad light, affecting the line of sight and driving safety. After washing the vehicle, rinse the blade with plain water, and use special windscreen wax cleaner to remove the wax layer on the windshield.
- To prevent excessive water pressure from damaging the blades, do not wash the blades directly with a water jet.

Maintenance Rules

- Clean windshield and blade regularly (preferably once a week or once every two weeks).
- Wipe the wiper regularly (preferably once a day or once every two days). When using a blade to wipe the windshield, keep the windshield fully wet. (When there is no rain, the washer liquid must be sprayed in advance).
- Clean the windshield with a special windshield washer fluid.

- Promptly clean mud and insect carcasses stuck to the windshield with a rag.
- When there are marks on the windshield caused by gravel, maintenance must be carried out timely. (It is recommended that windshield repair resin products should be used and the windshield should be replaced if marks are too large or too many.)
- Replace the wiper blades regularly, preferably once every six months.
- When cleaning the windshield, raise the wiper arm in advance. The specific operation method is as follows:
 1. On infotainment touchscreen, tap **Vehicle health** → **Overhaul** to enable front wiper maintenance. The wiper is then rotated down.
 2. Grasp the upper end of the wiper arm and carefully lift the wiper arm and blade assembly.

Tires

- For safe driving, tires must be made and sized to fit the vehicle, with good tread and standard tire pressure.

WARNING

- Using tires with excessive wear or insufficient/excessive pressure can result in accidents, severe injury, or death.
- Please follow all instructions in this manual regarding tire inflation and maintenance.

Tire Inflation

- Keep tires properly inflated to provide the best combination of

maneuverability, tread life, and driving comfort.

- Under-inflated tires can cause uneven tire wear, affect steerability and energy consumption, and are prone to leakage due to overheating.
- Over-inflated tires reduce riding comfort and are prone to damage from uneven roads. In severe cases, the risk of tire bursting poses severe threats to the safety of the entire vehicle. Over-inflation will also cause uneven wear and tear of tires, affecting tire service life.
- The vehicle is equipped with a tire pressure gauge. When tires are cold, you can decide whether to replenish tire pressure according to the tire pressure values displayed on the instrument cluster.
- Tire pressure should be measured while tires are at ambient temperatures. This means that it should be measured at least three hours after stop. If you must drive the vehicle before the tire pressure is measured, tires can still be considered at ambient temperatures as long as the traveled distance is not more than 1.6 km.
- It is normal that tire pressure reading measured while tires are hot (after travel of several kilometers) is 30-40 kPa (0.3-0.4 kgf/cm²) higher than when tires are cold. In that case, do not deflate tires in order to achieve the specified cold tire pressure reading; otherwise, the tire pressure will be insufficient.

REMINDER

- The recommended cold tire pressure is indicated on the label affixed to the driver's door frame.

REMINDER

- Tubeless tires have a self-sealing function when they are punctured. However, as the leak is usually very slow, as soon as the tire begins to depressurize, carefully look for the leak location.

Tire Checks

- Whenever checking tire inflation, check tires for damage, foreign body piercing and wear.
- Replace the tire if bumps, or tread or side damage are found. Tires should be replaced if any of the cases happens.
- Replace the tire if there are cracks on its side or if its fabric or cord can be seen.
- Replace tires with excessive tread wear.
- Tire treads are cast with wear bars. When the tread is even with the wear bar, its thickness is less than 1.6 mm. The adhesion of tires worn to this extent is very small on wet roads.

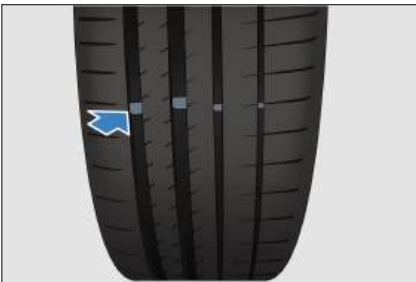

- Tires with exposed wear bars are experiencing serious performance loss and therefore must be replaced.

Maintenance

- In addition to proper inflation, proper wheel alignment also helps reduce tread wear.
- If uneven tire wear is found, go to a BYD authorized dealer or service provider and check the wheel alignment.
- Although the vehicle has been balanced in the factory, it needs to be re-balanced after running for a period of time.
- If there is some kind of continuous vibration while driving at high speeds (above 80 km/h), but not at low speeds, go to a BYD authorized dealer or service provider and check the tires.
- If a tire has been repaired, be sure to re-balance it.
- After installing a new tire or replacing a new wheel, always perform tire balancing.

CAUTION

- Improper placement of wheel balance blocks will not stick firmly and fall off, which will damage your vehicle or surrounding things while driving.
- Improper placement of wheel balance blocks will damage the aluminum alloy rims of your vehicle. Therefore, it is recommended to use original wheel balancers to keep balance.

Tire Rotation

- In order to make tires wear the same and prolong their service life, it is recommended to check the wear of the tire inner and outer tread every 10,000 km and conduct four-wheel alignment,

inspection and adjustment as well. Rotate the tires if necessary.

- Do not rotate tires when a spare tire is used for the vehicle.
- After tire replacement, go to a BYD authorized dealer or service provider for tire pressure matching.

Directional tires and wheels

- When purchasing replacement tires, you may find that some tires are "directional", which can only be rotated in one direction. If directional tires are used, only the front and rear wheels can be swapped in tire rotation.
- As shown:
 - ① Non-directional tires and wheels.
 - ② Directional tires and wheels.

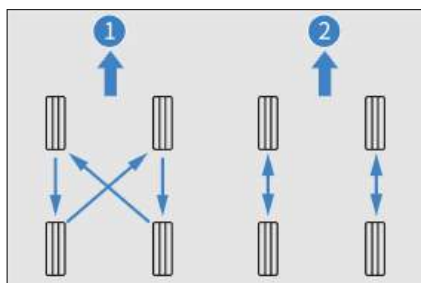

Replacing Tires and Wheels

- Original tires maximize performance, while providing the best combination of maneuverability, driving comfort and service life.
- It is recommended to replace with original tires at a BYD authorized dealer or service provider.
- Replacement of tires with different sizes, road ranges, rated speeds and maximum cold pressures (marked on the tire side) or mixed use of radial tires and diagonal tires can reduce

braking ability, driving force (ground adhesion) and steering accuracy.

- Unsuitable tires affect the maneuverability and stability of the vehicle, and may lead to accidents.
- Do not replace only one tire; otherwise it will severely affect the maneuverability of the vehicle.
- ABS works by comparing wheel speed. When replacing a tire, use a tire of the same size as the original tire. The size and structure of the tire affect wheel speed and may lead to uncoordinated system operation.
- If the wheel needs to be replaced, ensure that the specifications of the new wheel match those of the original wheel. New wheels are available for purchase at BYD authorized dealer or service providers. Please consult a BYD authorized dealer or service provider before replacing the wheels.

WARNING

- Please observe the following precautions to ensure proper vehicle maneuverability and control.
 - Do not mix radial tires, bias belted tires, or diagonal ply tires on the vehicle.
 - Do not use tires with dimensions other than those recommended by the manufacturer.

Fuses

All vehicle circuits are provided with fuses to prevent short circuit or overloading. These fuses are mounted in the underhood power distribution box (PDB), dashboard PDB, positive terminal PDB and rear compartment PDB, respectively. Fuse labels are included in the under-

hood, dashboard, and rear compartment PDBs, showing the correspondence of fuses with electrical components.

- ① Under-hood PDB
- ② Dashboard PDB
- ③ Rear compartment PDB

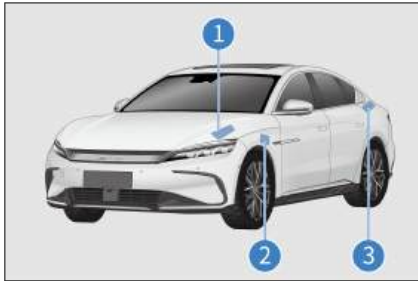

- The under-hood PDB is located on the left side under the hood. To open it, open the hood and its cover, locate the PDB and press the latch at the upper cover.
- The dashboard PDB is located on the left side of the dashboard. To access the dashboard fuses, remove the left

end panel of the dashboard and then the lower panel of the dashboard.

- The rear compartment PDB is located in the rear section of left-side C-pillar trim. To access the rear compartment PDB fuses, remove the access door on the left panel of the trunk.
- Replacement of blown fuses with ones of higher amperage can significantly increase the likelihood of damage to the electrical system.
- If there is no spare fuse with an amperage matching the circuit, use a fuse with lower amperage instead.

⚠ WARNING

- Do not use fuses with amperage higher than the rated ampere value or any other solution to replace the fuses, as this can cause serious damage or even a fire.
- If a fuse blows, it is recommended to check or replace the fuse at a

WARNING

BYD authorized dealer or service provider.

Under-Hood PDB Nameplate

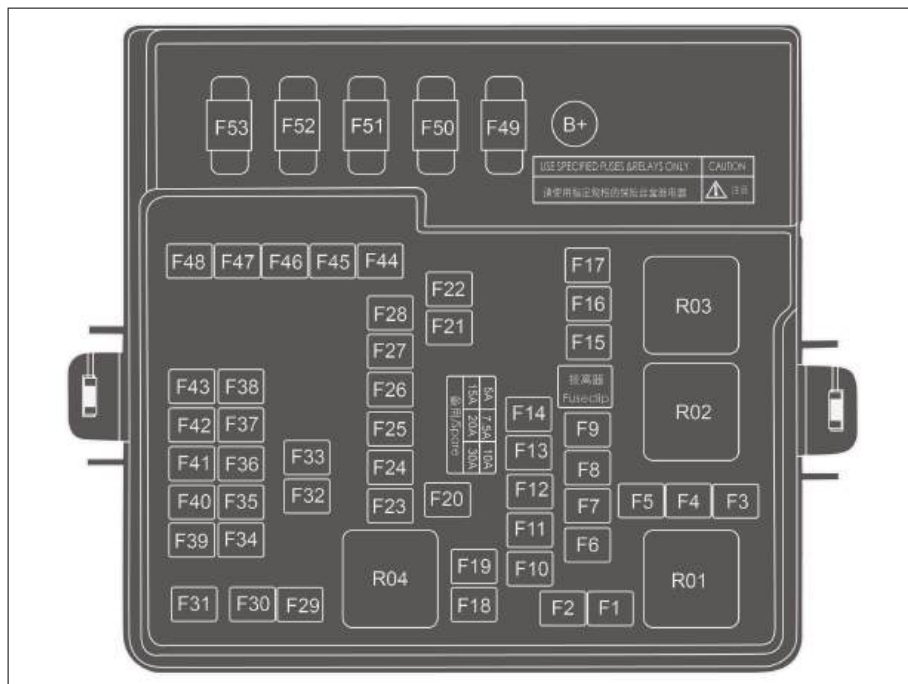

Fuses

No.	Ampere (A)	Protected Component or Circuit
F1	-	-
F2	60	Dashboard PDB
F3	-	-
F4	-	-
F5	-	-
F6	-	-
F7	-	-

No.	Ampere (A)	Protected Component or Circuit
F8	-	-
F9	5	Charging and distribution assembly
F10	15	Left combination headlight
F11	15	Right combination headlight
F12	10	Battery manager
F13	10	Front motor controller
F14	10	Rear motor controller
F15	5	Brake light switch
F16	-	-
F17	-	-
F18	-	-
F19	-	-
F20	30	Rear defroster
F21	30	Front wiper
F22	20	VTOV
F23	20	Electrically controlled cooling water pump 2
F24	15	Electrically controlled cooling water pump
F25	7.5	Compressor
F26	10	USB
F27	15	Auxiliary power
F28	15	Rear-seat auxiliary power
F29	25	External amplifier
F30	60	ESC
F31	-	-
F32	25	External amplifier

No.	Ampere (A)	Protected Component or Circuit
F33	5	Battery manager
F34	15	Steering wheel heater
F35	5	Rear body control module
F36	5	Gearshift panel
F37	7.5	ETC
F38	10	SRS
F39	7.5	ADAS
F40	5	Instrument Cluster
F41	5	EPS
F42	5	ESC
F43	-	-
F44	60	ESC
F45	40	Blower
F46	7.5	Integrated thermal management module
F47	7.5	ADAS
F48	-	-
F49	-	-
F50	70 / 100	C-EPS/R-EPS
F51	80	Electric fan
F52	-	-
F53	200	Battery

Dashboard PDB Nameplate

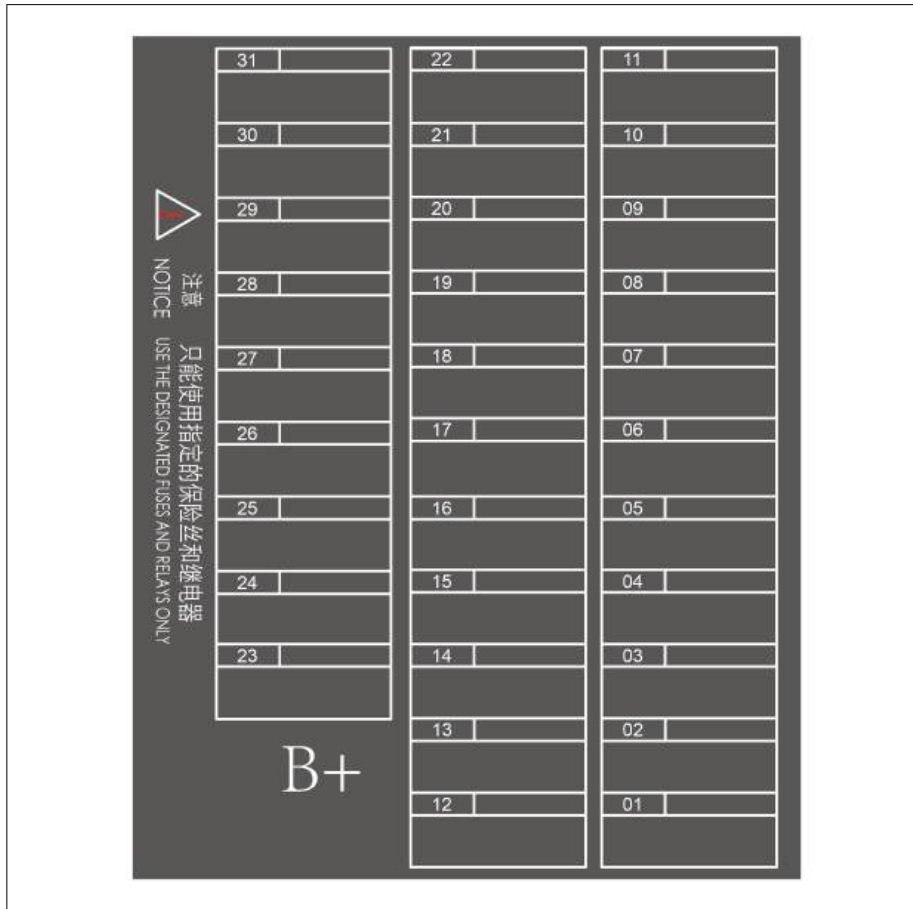

No.	Ampere (A)	Protected Component or Circuit
01	30	Rear body control module
02	-	-
03	-	-
04	20	Front left window
05	20	Front right window
06	-	-

No.	Ampere (A)	Protected Component or Circuit
07	5	Gearshift panel
08	20	Infotainment system
09	-	-
10	7.5	Panel ambient light
11	7.5	Combination switch
12	-	-
13	-	-
14	7.5	Wireless charger
15	10	Diagnosis port
16	5	Instrument Cluster
17	7.5	Smart access
18	5	Vehicle controller
19	5	HUD
20	-	-
21	30	Front left power seat
22	30	Front right power seat
23	-	-
24	-	-
25	-	-
26	-	-
27	-	-
28	-	-
29	-	-
30	-	-

Rear Compartment PDB Nameplate*

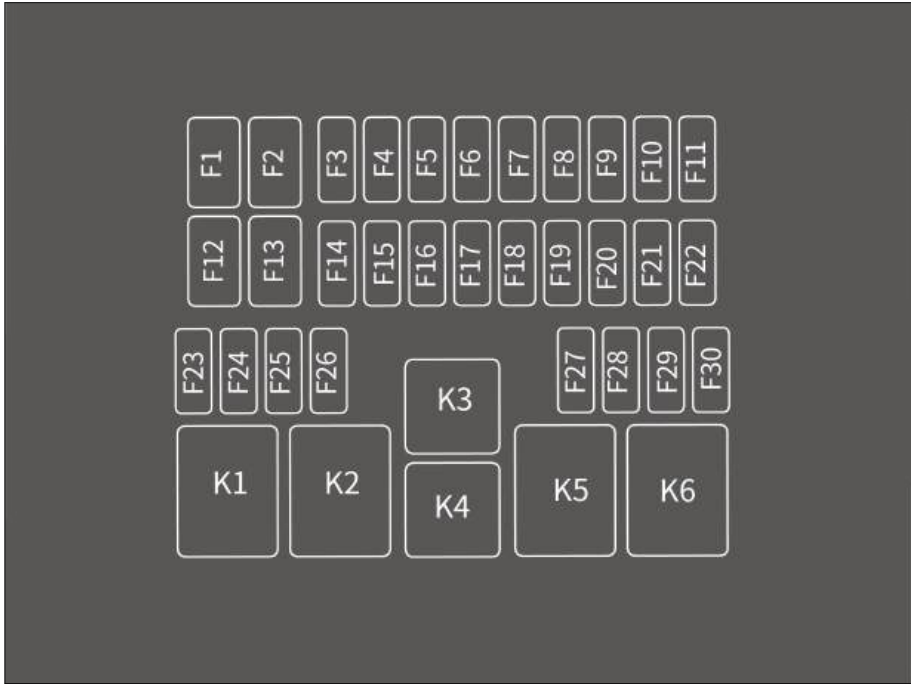

Fuses

No.	Ampere (A)	Protected Component or Circuit
F1	40	Front left pre-tensioner motor
F2	40	Front right pre-tensioner motor
F3	30	Rear left power seat
F4	10	Rear right seat
F5	5	High-frequency receiving module
F6	15	Suspension module
F7	30	Rear body control module
F8	30	Rear body control module

No.	Ampere (A)	Protected Component or Circuit
F9	7.5	RSE
F10	10	Left combination tail light
F11	10	Right combination tail light
F12	25	External amplifier
F13	25	External amplifier
F14	7.5	ADAS
F15	20	External amplifier
F16	20	Left rear window
F17	20	Right rear window
F18	5	On-board charger
F19	5	UWB*
F20	-	-
F21	-	-
F22	-	-
F23	-	-
F24	-	-
F25	-	-
F26	-	-
F27	-	-
F28	-	-
F29	-	-
F30	-	-
K1	-	-
K2	-	-
K3	-	-
K4	-	-
K5	-	-

No.	Ampere (A)	Protected Component or Circuit
K6	-	-

07

WHEN FAULTS OCCUR

When Faults Occur.....188

When Faults Occur

If Smart Key Battery is Exhausted

If the smart key indicator does not flash and the vehicle cannot be started using the start function, the smart key battery may be exhausted. In that case, it is recommended to contact a BYD authorized service provider as soon as possible to change the battery, and you can start the vehicle in no-power mode.

CAUTION

- Do not place the smart key in a position exposed to high temperature.
- Do not hit or slam the key with hard objects.
- Magnetic fields generated by nearby radio stations, substations or airport radio transmitters may interfere with the normal operation of electronic smart keys.
- After locking the vehicle and arming its anti-theft alarm system, keep the key away from the vehicle; otherwise the automatic card finding function of the vehicle will consume the power of the low-voltage battery and the smart key.

1. Use the mechanical key to unlock the vehicle.
2. Press the brake pedal and the START/STOP button. The smart key warning light comes on and the speaker in the vehicle gives a beep.

3. Keep the smart key close to the no-power mode sign on the auxiliary dashboard within 30 seconds after the speaker beeps. The smart key warning light turns out, and the vehicle can be started.

- The no-power mode sign is located in the cubby box.

4. Start the vehicle within five seconds after the speaker beeps again.



Emergency Shutdown System

- The emergency shutdown system is activated and the high-voltage system is automatically shut down when the following conditions are met:
 - The airbags do not deploy after a frontal collision.
 - There is a rear collision.
 - The vehicle system is faulty.
- The OK indicator goes off if any of the above situations occurs.
- Activating the emergency shutdown system in the noted types of collision minimizes the risk of injuries or accidents.
- The vehicle system cannot be switched into the OK status once the emergency shutdown system is activated. In that case, it is recommended to contact a BYD authorized dealer or service

provider for help. The system is turned off immediately even if the ignition is switched on. Contact a BYD authorized dealer or service provider as soon as possible.

Vehicle Fire Rescue

In case of fire, continue to operate the vehicle as follows according to the actual situation:

1. Switch the ignition off, and leave the vehicle.
2. On the precondition that personal safety is ensured, if the fire is small and slow, use a dry powder fire extinguisher to put out the fire, and call for help immediately.
3. If the fire is large and growing quickly, stay away from the vehicle and wait for rescue.



CAUTION

- Wear insulated gloves during vehicle disassembly. Use fire extinguishers of designated type. Water or incorrect fire extinguishers may cause electric shock.
- In the event of other special conditions that cause flying projectiles (such as interior trims and glass), stay away from the vehicle and promptly ask a BYD authorized dealer or service provider to come to the site for handling.

Battery Leakage Rescue

After a collision, if there is battery leakage, an acrid smell inside the vehicle, visible acid flow outside the vehicle, or any smoke with the battery pack:

1. Switch the ignition off, and disconnect the low-voltage battery if conditions permit.
2. It is recommended to call immediately a BYD authorized dealer or service provider for rescue.

Collision Rescue

In case of collision, operate the vehicle as follows according to the actual situation:

1. Switch the ignition off, and disconnect the low-voltage battery if conditions permit.
 2. Call immediately a BYD authorized dealer or service provider for rescue.
 3. Carry out a simple inspection, if conditions permit: Check whether any edge of the high-voltage battery tray is cracked and whether any obvious liquid flows out.
- If skin comes in contact with leaked fluid, wash it immediately with plenty of water for 10-15 minutes. If there is still any discomfort, apply 2.5% calcium gluconate ointment, or soak in 2% to 2.5% calcium gluconate solution. If the condition does not get better or discomfort persists, seek medical help immediately.



WARNING

- Do not touch any spilled liquid, and stay away from a leaking vehicle or high-voltage battery.
- Do not dispose of the leaked fluid into the water or soil or other environment.
- The vehicle system operates with high-voltage DC power. It generates a lot of heat before and after vehicle start-up and when the vehicle is powered off. Watch

⚠ WARNING

out for high pressures and high temperatures.

- Do not disassemble, move, or alter high-voltage battery components and connecting cables as their connectors can cause serious burns or electric shock and may result in personal injury or death. The orange cables are part of high-voltage wiring harness. Users must not repair the vehicle's high-voltage system by themselves. If any repair is required, it is recommended to go to a BYD authorized dealer or service provider for repair.
- The remote control key and high-voltage components of the vehicle may affect and harm people carrying medical devices.

If the Vehicle Needs Towing

If the vehicle needs towing, it is recommended to contact a BYD authorized dealer or service provider, a professional towing service, or the organization you joined for roadside assistance.

⚠ WARNING

- The vehicle must not be towed by other vehicles using only ropes or chains.

Recommended towing methods:

- Flatbed device
- If the vehicle fails and needs towing, a flatbed is recommended. When the vehicle is being towed, keep its four wheels off the ground. Towing

the vehicle on front or rear wheels alone may damage high-voltage components.

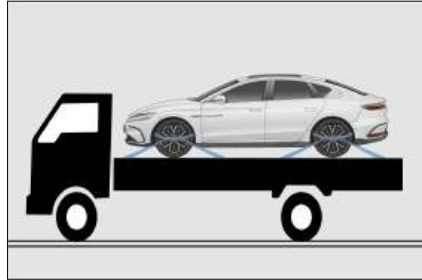

⚠ CAUTION

- When moving the vehicle on a flatbed device, make sure that the vehicle being moved is properly secured to prevent it from sliding back.
- It is recommended to use professional tire straps and tighteners, and over-the-wheel binding is recommended for securing moved vehicles.
- When fixing the vehicle, do not pass the fixtures such as straps and ropes through the wheels or tie them on the chassis, suspension and other body parts to prevent damaging the vehicle.
- When transporting a vehicle, make sure that the wheels of the moved vehicle cannot turn to avoid damage to the vehicle.

Tow Eye

The installation point of vehicle tow eye is shown in the illustration.



- If the vehicle needs rescue, call a professional rescue or the customer service number.
- In emergency situations where the vehicle needs rescue using the tow eye, observe the following to avoid vehicle damage or personal injuries.
 - The towing vehicle must be in good conditions and the towed vehicle in Neutral; the tow speed must be no more than 5 km/h.
 - Never use jerking actions to pull the vehicle.
 - The towed vehicle must not carry any person except for the driver or tow any trailer.
 - Both towing and towed vehicles must have their hazard warning lights on.
 - To avoid damages to the vehicle, only the in-vehicle tow eye can be used.
 - The distance between the towing and towed vehicles must be more than 4 meters but less than 10 meters.
 - The width and weight of the towed vehicle must not be greater than those of the towing vehicle.
 - When towing the vehicle, ensure its surroundings are unobstructed and have enough space and no person is close to the towing device.
 - When freeing the vehicle, control to make it travel in the direction of tow

force. Dragging the vehicle from the side or vertically is prohibited.

- The towed vehicle must be controlled by a driver inside the cabin, with the steering and braking systems in normal conditions.

WARNING

- Never rescue a stuck or high-centered vehicle with tow eyes. Call a professional rescue or the customer service number.
- If the steering or braking system of the towed vehicle fails, contact a professional rescue or call the customer service number. Do not tow the vehicle directly.

If a Tire Goes Flat

- In case of a flat tire, slow down, keep straight and drive off the busy road to a safe place.
- Park on solid, flat ground and avoid motorway forks.
- Engage the EPB and press the "P" button.
- Power off the vehicle and turn on the hazard warning light.

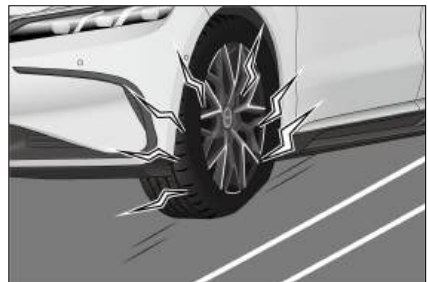

- Be sure to have all passengers get off the vehicle and ask them to go to a safe place away from crowded traffic.

- To prevent slipping, secure the vehicle by wedging the tire diagonally against the flat tire.

CAUTION

- Do not continue driving with a flat tire. Even a short distance of driving with flat tire can cause irreparable damage.

In-Vehicle Tools

- In-vehicle tools (except for warning triangle) are stored in a tool box under the trunk cover flap, and the warning triangle is fixed to the trunk lid.

- ① Warning triangle
- ② Reflective vest
- ③ Tire repair kit*
- ④ Rocker wrench*
- ⑤ Lug nut cover removal clamp*
- ⑥ Wheel hub cover removal hook*

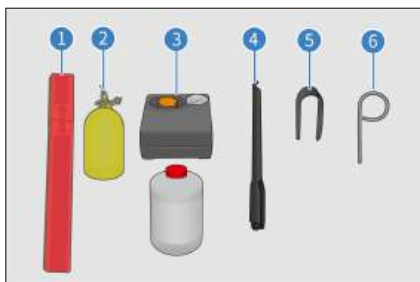

- In an emergency where you need to service the vehicle yourself, you must know how to use these in-vehicle tools and their locations.

Placing the warning triangle

REMINDER

- When parking for repair, remember to place the red

REMINDER

triangle side facing oncoming vehicles, 100-200 meters away from the vehicle. After the repair, recover the warning triangle for future use.

The warning triangle is used to warn vehicles coming from behind and to avoid collisions due to high speed or late braking.

How to use the warning triangle:

1. Take the warning triangle out of its box.
2. Attach the ends to form a triangle.
3. Mount the supports as shown.



Using Tire Repair Kit*

- The tire repair kit is used to seal small cuts, especially cuts in tread pattern. It is just an emergency solution for you to drive to the nearest service center, and only for short emergency stretches, even if the tire is not deflated.

WARNING

- At most, the tire repair kit can repair holes that are on the tire tread and are within 6 mm in diameter. Do not use the kit on holes with larger diameters or in

! WARNING

other tire positions, but call for roadside assistance instead.

- Tire sealant is highly flammable and harmful to health. Take necessary precautions to prevent fire and avoid contact with skin, eyes, and clothing; keep away from children; and do not inhale its vapor.

In case of contact with tire sealant:

- If tire sealant comes into contact with the skin or gets into the eyes, thoroughly flush the affected body part immediately with plenty of clean water.
- Change contaminated clothing immediately.
- In case of an allergic reaction, seek medical attention immediately.
- If tire sealant is ingested by accident, rinse mouth thoroughly and drink plenty of water immediately. Do not induce vomiting, but seek medical attention immediately.

Using the tire repair kit

- See labels on the inflator and tire sealant for usage of the kit.
- If the inflator needs to be connected to a power source, plug the inflator into the vehicle's 12V socket, start the vehicle, and switch on the inflator. The tire sealant is then filled through the inflator hose into the tire along with air.



! CAUTION

- Make sure the inflator switch is off when you plugging the power supply into the 12V socket in the vehicle.
- Do not use the inflator continuously for more than 10 minutes at a time.
- Observe the tire pressure reading on the inflator.
 - If the tire pressure does not reach 180 kPa (1.8bar) within 10 minutes (red area shown in the figure), turn off the inflator. You are recommended to contact a BYD authorized dealer or service provider.



- If the tire pressure reaches between 180 and 320 kPa (1.8-3.2bar) (green and yellow areas shown in the illustration), remove the kit as soon as possible and drive at a speed below 80 km/h within one minute, with the furthest driving distance not

exceeding 10 km, so that the tire sealant is evenly distributed within the tire.

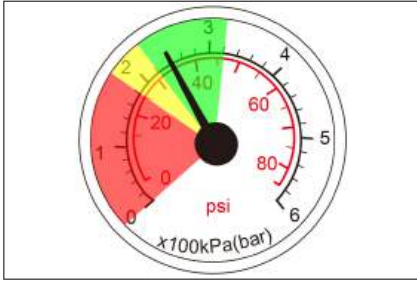

- Stop to check the repaired tire and the tire pressure reading on the inflator.
- If the tire pressure is greater than 220 kPa (2.2 bar), drive to the nearest service center at a speed below 80 km/h.
- If the tire pressure is between 130 and 220 kPa (1.3-2.2 bar), repeat the process to fill the tire sealant into the tire and observe the tire pressure gauge reading on the inflator.
- If the tire pressure does not reach 130 kPa (1.3 bar), contact a BYD authorized dealer or service provider.

REMINDER

- Using tire repair kit on damaged tires is only an emergency solution. Please change the tires at a professional repair center as soon as possible. It is recommended that you contact a BYD authorized dealer or service provider and inform the maintenance technician that tire sealant has been used.
- Avoid hard acceleration and high-speed turns.
- Do not exceed the 80 km/h maximum speed limit and replace flat tires as soon as possible. Do

REMINDER

not drive further if the vehicle experiences strong vibration, unstable performance, or noise.

- When the tire sealant is about to expire (see the label on the canister for exact date), replace it with a new one.
- After using the tire repair kit, it is recommended to purchase new tire sealant at a BYD authorized dealer or service provider.

Replacing Tires*

Wedging the wheel

1. Wedge the tire diagonally against the flat tire to prevent the vehicle from rolling.

- To do so, place the wedges in front of the front wheels or behind rear wheels.



Loosening lug nuts

2. Remove the decorative cover of lug nuts with the wheel hub cover removal hook or lug nut cover removal clamp (depending on vehicle models) in the trunk toolkit.

- Loosen lug nuts before raising the vehicle.

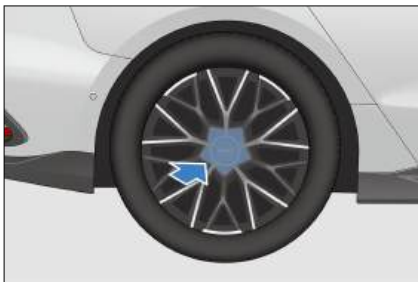

3. Turn the rocker wrench counterclockwise to loosen all lug nuts of the deflated tire.



REMINDER

- Hold the end of the rocker wrench and press it down, and do not allow the rocker wrench to slide off the nut.
- Do not remove the nut, and just loosen it by one to two turns.

Positioning the jack

4. Position the jack at the correct jacking point as shown.

- Ensure that the jack is placed on a flat and solid ground.

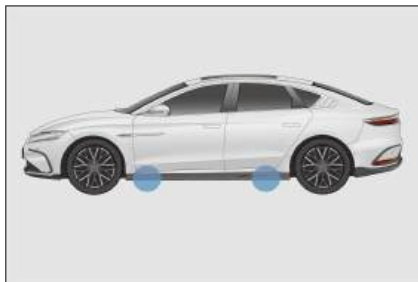

WARNING

When you jack up the vehicle, observe the following rules to reduce the likelihood of injury:

- When you jack up the vehicle, do not have any part of your body under the vehicle. Otherwise, personal injury may be caused.
- Do not power on the vehicle when it is being jacked up.
- Park the vehicle on flat and solid ground, engage the EPB and put the gearshift lever in neutral. If needed, secure the vehicle by wedging the tire diagonally against the flat tire.
- Ensure that the jack is placed at the correct jacking point. Jacking up the vehicle at an incorrect jack point will damage the vehicle or tip the vehicle off the jack, causing personal injury.

CAUTION

- Ensure that the jack is properly raising the vehicle, otherwise it may damage the vehicle.

Jacking up the vehicle

5. After confirming that the vehicle has no passenger onboard, jack up the vehicle to a height allowing for spare tire installation.

- Installing a spare tire requires more distance from the ground than removing a deflated one.



- When lifting the vehicle, insert the rocker wrench into the jack and rotate it clockwise.
- When the jack is in contact with the vehicle and begins to lift the vehicle, verify again that the jack is in the correct position.

WARNING

- Never get under a vehicle supported only by a jack.

Replacing wheels

6. Remove lug nuts and replace the tire.

- Roll the spare tire to the mounting position, with the bolts aligned with the wheel holes. Then hold up the wheel until the top bolt passes through the screw hole.
- Rotate the tire and push it back until all other bolts pass through the holes.



- Before installing the wheel, remove corrosion from the mounting surface with a wire brush or the like.

CAUTION

- When you install a wheel, ensure that the mounting position is contacted well, otherwise loose lug nuts will cause the wheel to come off during driving.

Reinstalling lug nuts

7. Reinstall all lug nuts.

- When reinstalling lug nuts, tighten the lug nuts by hand to the greatest extent, then push the wheel backward and tighten the lug nuts further.

WARNING

- Do not apply motor oil or lubricant on bolts or nuts, as this can over-tighten the nuts and thus damage the bolts. The loose nuts so caused would lead the wheels to come off, causing serious accidents.

Lowering the vehicle

8. Lower the vehicle completely, tighten the lug nuts, and install the decorative cover for lug nuts.

- Lower the vehicle and remove the jack.



! REMINDER

- Tighten the nuts with a rocker wrench. Do not use other tools or any lever other than your hands, such as hammers, tubes, or feet.
 - Ensure that the rocker wrench holds the nut tightly.
- Tighten the nuts alternatively in the sequence shown, each a bit a time. Repeat the action until the lug nuts are torqued to the specification.



! CAUTION

- Before lowering the vehicle, make sure that no part of your body and no person in the vicinity of the vehicle will be injured by the vehicle's descent.
- Lug nuts must be torqued to 130 N · m after wheel replacement. Otherwise, loose nuts would cause the wheel to come off, causing serious accidents.

After wheel replacement

9. Check the pressure of the replacement tire.
- Adjust the tire pressure to the specification. If the pressure is lower than the specification, slowly drive to a nearby service station to inflate the tire to the correct pressure value.

- Be sure to mount the tire valve cap; otherwise dust and moisture will enter the valve stem and cause air leakage. If the valve cap is lost, use a new one as soon as possible.

10. Properly store all tools and the flat tire.

- Have the flat tire repaired by a technician.

! REMINDER

- Before driving, you should verify that all tools and flat tires are kept in a storage area to reduce the possibility of personal injury in case of collision or emergency braking.

08

SPECIFICATIONS

Vehicle Data.....	200
Information.....	203

Vehicle Data

Vehicle Data

Dimensions:

Item	Parameter
Length * Width * Height (mm) (side mirrors not included in width)	4995*1910*1495
Wheelbase (mm)	2920
Front track (mm)	1640
Rear track (mm)	1640
Front overhang (mm)	975
Rear overhang (mm)	1100
Approach angle (°)	≥13
Departure angle (°)	≥14

Vehicle mass:

Item	Parameter
Curb weight (kg)	2250
Front axle load (kg)	1105
Rear axle load (kg)	1145
Max. allowable total mass (kg)	2660
Front axle load at max. allowable total mass (kg)	1220
Rear axle load at max. allowable total mass (kg)	1440
Number of occupants (persons)	5

Drive motor:

Item	Parameter
Model	Front: TZ200XSU; rear: TZ200XSE
Type	Permanent magnet synchronous motor

Drive type	4WD
Rated power/speed/torque (kW/rpm/Nm)	Front: 65/4400/140 Rear: 65/4775/103
Peak power/speed/torque (kW/rpm/Nm)	Front: 180/15000/350 Rear: 200/15000/350

Vehicle power and economy:

Item	Parameter
Max. design speed (km/h)	180
Max. gradeability (%)	≥50
Power consumption per 100 km under comprehensive working conditions (kWh/100 km)	18.8 (WLTC)

Wheels and tires:

Item	Parameter
Tire specification	245/45/R19
Tire pressure (kPa)	250
Wheel dynamic balance requirement (g)	≤10

Wheel alignment values (at curb weight):

Item	Parameter
Front camber (°)	-0.5±0.75
Front toe-in (mm)	0±2
Kingpin inclination angle (°)	12.25±0.75
Kingpin caster angle (°)	2.75±0.75
Rear camber (°)	-0.75±0.75
Rear toe-in (mm)	3±2

Braking system:

Item	Parameter
Free stroke of brake pedal (mm)	≤5

Front brake disc thickness (mm)	32
Rear brake disc thickness (mm)	16
Front friction plate thickness (mm)	12
Rear friction plate thickness (mm)	6.5

High-voltage battery:

Item	Parameter
Type	Lithium iron phosphate battery
High-voltage battery rated capacity (AH)	150

Seats:

Seats	Item	Parameter
Front Seats	Forward and backward moving spaces for front seat (seat cushion depth measured)	30 mm forward from the farthest slide rail stroke
	Normal service conditions of front seatbacks	Seatback 26° forward and 40° backward from designed position, slide rail 210 mm forward and 30 mm backward from designed position; slide rail inclination: 4.5°
Rear Seats	Normal service conditions of seatbacks	Seatback angle 30°; seatback 4° forward and 4° backward from designed position; no slide rail

Fluid:

Item	Model	Filling Quantity
Transmission gear oil	Castrol BOT384	0.85±0.1 L (front assembly)
		0.95±0.1 L (rear assembly)
Coolant	Ethylene glycol long-acting anti-rust antifreeze	9.7 L
	Coolant ice point: -40°C	
Brake fluid	DOT4/HZY6	1.15±0.2 L

Information

Vehicle Identification

- ① VIN attached on the front of transmission assembly housing
- ② VIN attached on the side of the hood
- ③ VIN attached on the front windshield cross sill
- ④ VIN attached inside the trunk lid
- ⑤ VIN attached on the front anti-impact beam



- ⑥ VIN attached on the lower corner of driver's door
- ⑦ VIN attached on the left rear door sill
- ⑧ VIN attached on the left rear wheel envelope

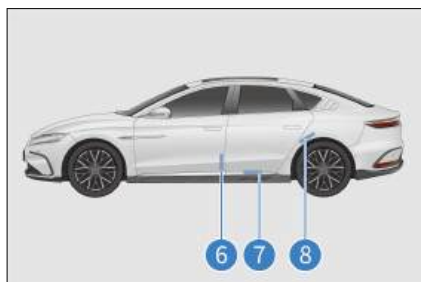

VIN is engraved on the lower beam of the front passenger seat.



Note: After connecting the VDS, the VIN can be found in the upper right corner of the screen for the corresponding model. For details, please refer to the VDS operation manual.

Vehicle Nameplate

- ① The vehicle nameplate is attached to the lower part of the right B-pillar:

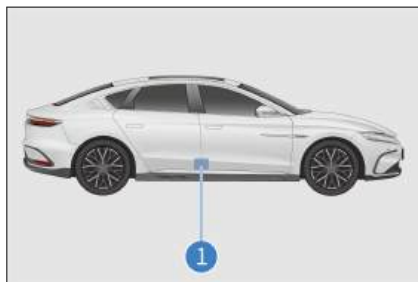

Model and Serial Number of Drive Motor

- ① The model and serial number of rear drive motor are engraved on the left groove of the trunk lid*.
- ② The model and serial number of front drive motor are engraved on the front drive motor housing.

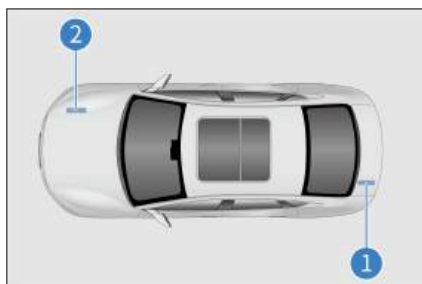

Warning Labels

- ① A/C system and cooling fan sticker
- ② Battery location sticker



Side airbag warning labels are attached on the lower part of the left and right B-pillars.



The airbag warning label is printed on the right sun visor.

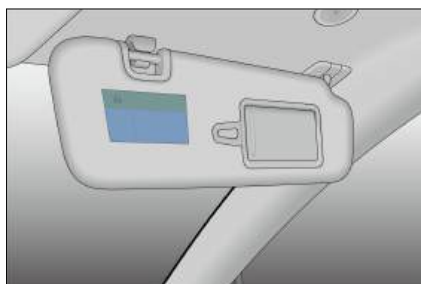

The tire pressure label is attached on the lower part of the left B-pillar.

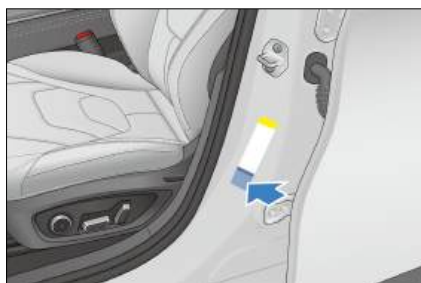

The AC charging warning label is attached on the inner side of the charge port door.



Declarations of Conformity

Smart Key



Uzbekistan
 Model: D0-92, D1-92



EU countries
 Model: D0-92, D1-92



Brazil
 Model: D0-92, D1-92
 This equipment is not entitled to protection against harmful interference and may not cause interference to duly authorized systems.

FCC ID: 2A5DHD0-315

The United States

FCC ID: 2A5DHD1-315

Model: D0-315, D1-315



Japan
 Model: D0-315, D1-315

Radio Frequency



The vehicle has different types of radio equipment. The manufacturers of the radio equipment declare that the RF Modules are in compliance with Directive 2014/53/EU. The full text of the EU declaration of conformity is available at the following Internet address: <https://cn-prod.byd.com/eu/eu-doc>.

Numerics

12V Auxiliary Power..... 156

A

A/C Operation Interface..... 145
A/C Settings Interface..... 144
A/C System Maintenance..... 174
A/C Vents..... 149
About BYD App..... 152
Account Registration..... 152
Acoustic Vehicle Alerting System (AVAS)..... 127
Adaptive Cruise Control (ACC)* 107
Adjusting Front Seat with Power*.. 56
Adjusting Rear Seats* 59
Air Purification System..... 150
Airbag Triggering Conditions and Precautions..... 18
Airbags..... 15
Anti-lock Braking System (ABS)... 135
Anti-theft Alarm System* 27
Automatic Vehicle Hold (AVH)..... 105
Automatic Vehicle Washing..... 167

B

Bill Box..... 154
Blind Spot Assist (BSA)* 123
Bluetooth Call..... 143
Brake Fluid..... 173
Break-in Period..... 95
BYD Assistant..... 143

C

Carrying Items in the Passenger Area 96
Carrying Luggage..... 96
Charging..... 82
Charging Safety Warnings..... 78
Child Restraint System..... 23
Coolant..... 172

D

Data Collection and Processing..... 28
Discharging Device* 89
Door Bins..... 154
Driving..... 100
Driving Precautions..... 106
Driving Safety Systems..... 132

E

Electronic Child Protection Lock... 55
Electronic Smart Key..... 46
Emergency Shutdown System..... 188
Emergency Steering Assist (ESA)* 122
Emergency Vehicle Locking with Mechanical Key..... 53
EPB Switch..... 102

F

File Management..... 144
Fire Prevention..... 98
Front Seat Cup Holder..... 153
Front Windshield Wipers and Washer 68
Function Definition..... 146
Fuse Location..... 177

G

Gear Shift Controls..... 101
Glasses Case..... 154
Glove Box..... 153
Grab Handles..... 155

H

Hazard Warning Light Switch..... 73
High Beam Assist (HMA)* 119
High-Voltage Battery..... 91

I

If a Collision Occurs.....	189
If a Fire Occurs.....	189
If a Tire Goes Flat.....	191
If Smart Key Battery Is Exhausted	188
If the High-Voltage Battery Leaks.	189
If the Vehicle Needs Towing.....	190
Indicators/Warning Lights.....	35
Individual Center and Vehicle Management.....	153
Infotainment Touchscreen.....	142
Installing Child Restraint Systems.	24
Instrument Cluster View.....	34
Intelligent Cruise Control (ICC)* ...	111
Interior Cleaning.....	167

K

Keys.....	46
Knee Airbags.....	17

L

Light Switches.....	64
Loading the Trunk.....	97
Locking/Unlocking the Trunk.....	51
Locking/Unlocking with Mechanical Key.....	48
Locking/Unlocking with Smart Key	49
Low-Voltage Battery.....	94

M

Maintenance Plan.....	162
Maintenance Schedule Requirements	162
Manual Vehicle Washing.....	166
Mode Switches.....	72

N

Navigation Bar.....	143
---------------------	-----

O

Odometer Switch.....	71
Opening and Closing the Hood....	172

P

Paint Maintenance Tips.....	165
Panoramic Sunroof.....	73
Panoramic View System*.....	128
Parking Assist System*.....	129
PCW.....	113
Power Side Mirrors.....	137
Power Steering Wheel Adjustment	62
Power Window Switches.....	69

R

Releasing EPB Manually.....	103
Replacing Wiper Blades.....	138
Reservation Charging.....	87

S

Safety Check Before Driving.....	100
Saving Energy and Extending Vehicle Service Life.....	95
SD Card Slot.....	157
Seat Belt Overview.....	12
Seat Precautions.....	55
Seat Side Airbags.....	17
Seatback Pockets.....	155
Self-Maintenance.....	169
Side Curtain Airbags.....	18
Snow Chains.....	138
Starting the Vehicle.....	99
Steering Wheel Switches.....	60
Sun Visor.....	155
Sunroof Maintenance.....	171

Switching on A/C with Cloud Service
App..... 151

T

Tire Pressure Monitoring..... 125
Tires..... 175
Traffic Sign Recognition (TSR)..... 117
Trailer Towing..... 95

U

USB Ports* 156
Using Seat Belts..... 13

V

Vehicle Cleaning..... 166
Vehicle Corrosion Prevention..... 165
Vehicle Identification Number..... 203
Vehicle Servicing..... 164
Vehicle Storage Precautions..... 171

W

Wading into Water..... 97
Warning Labels..... 204
Washer..... 173
Wiper Blades..... 174
Wipers..... 138
Wireless Phone Charger..... 157

Abbreviations

Abbreviations

Terminology	Name	Terminology	Name
ECU	Electronic Control Unit	EDR	Event Data Recorder
ECO	Ecology, Conservation, Optimization	SPORT	Sport
NORMAL	Normal	E-Call	Emergency Call
EPB	Electronic Parking Brake	AVH	Auto Vehicle Hold
ACC	Adaptive Cruise Control	PCW	Pedestrian Collision Warning
AEB	Automatic Emergency Braking	LDW	Lane Departure Warning
LDP	Lane Departure Prevention	TPMS	Tire Pressure Monitoring System
AVAS	Acoustic Vehicle Alert System	ABS	Antilock Braking System
ESC	Electronic Stability Controller	VDC	Vehicle Dynamics Control
TCS	Traction Control System	HHC	Hill Hold Control
HBA	Hydraulic Brake Assit	CDP	Controller Deceleration Parking
MAX	Maximum	MIN	Minimum

BUILD YOUR DREAMS

Edition Date: 08.2024 EN_V4